



# PRICE OUTLINE

REX ROWLES  
526 Rowles Rd  
Karranadgin  
WA 6460

REX ROWLES  
526 Rowles Rd  
Karranadgin  
WA 6460

PH: 0438 082 813

FAX: N/A

**PROPOSAL NO** 41243

**PROPOSAL DATE** 12-09-2019

**ACCOUNT NO** 3113

**SERVED BY** Craig Whyte

STOCKCODE	DESCRIPTION	ORD QTY	UNIT PRICE (Ex GST)	TOTAL (Ex GST)
RT4500-CHA	4,500 LITRE (1,000 GALLON) PREMIUM CORRUGATED TANK - MONUMENT/CHARCOAL  **NORMALLY - \$979.00 + GST EACH**  BOTH TANKS INCLUDE: - - MANHOLE & LEAF STRAINER @ 12 - 90MM PVC MESH OVERFLOW @ 6 - 50MM BRASS THREADED OUTLET & BALL VALVE TAP @ 12 - 20 YEAR WARRANTY GUARANTEE	2.0	904.55	\$1,809.09
ITB135001.2	13500 LITRE BUNDED TANK 1.2SG *13500LTR POLYETHYLENE (LDPE) DUAL SKIN BUNDED TANK - SUITABLE FOR DIESEL STORAGE** (DIMENSIONS - 3550MM DIA x 2850MM HIGH)  TANK INCLUDES: - VENTED 455MM SCREW LID ON EXTERNAL TANK - 355MM SCREW LID ON INTERNAL TANK - LIQUIDATOR 2 LEVEL GAUGE FITTED - 2" INTERNAL FILL PIPE TO FLOOR TO PREVENT STATIC BUILD UP - 2" INLET WITH ALLUMINIUM MALE CAMLOCK, NON-RETURN VALVE. - 2" LOW LEVEL OUTLET WITH TAP, ALLUMINIUM CAMLOCK & DUST PLUG - COLOUR SLATE GREY	1.0	13,728.00	\$13,728.00
JRR50000-SMC	50,000 LITRE (11,000 GALLON) PREMIUM FLATWALLED TANK - SMOOTH CREAM  **NORMALLY -\$7,272.00 + GST EACH**  BOTH TANKS INCLUDE: - - MANHOLE & LEAF STRAINER @ 12 - 90MM PVC MESH OVERFLOW @ 6 - 50MM BRASS THREADED OUTLET & BALL VALVE TAP @ 12 - 20 YEAR WARRANTY GUARANTEE  **PRICE INCLUDES DELIVERY TO GOOMALLING - W.A**	2.0	6,363.64	\$12,727.28

Coerco Pty Ltd  
ABN: 54 145 356 565

PO Box 319

9 Huggett Drive  
Dalwallinu WA 6609

Phone 08 9661 0610  
Fax 08 9661 1515

Freecall 1800 646 277  
Email [info@coerco.com.au](mailto:info@coerco.com.au)

Perth | Darwin | Brisbane | Sydney | Melbourne | Adelaide



Pond Shape	Square
Maximum Surface Area	1385 m <sup>2</sup>
Average Surface Area	1300 m <sup>2</sup>
Pond Depth	0.58 m
Freeboard Height	0.5 m
Total Depth	1.08 m
Total Volume (exc. Freeboard)	754 m <sup>3</sup>
Slope Ratio (H:W)	1:2
Lining Material	Compacted Clay

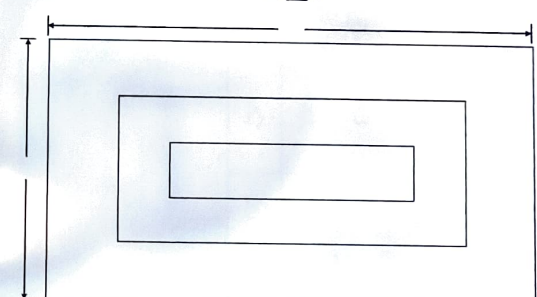
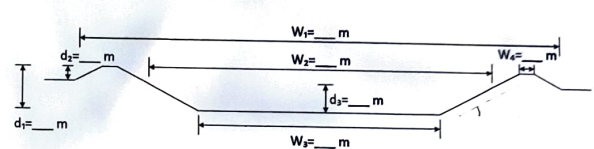
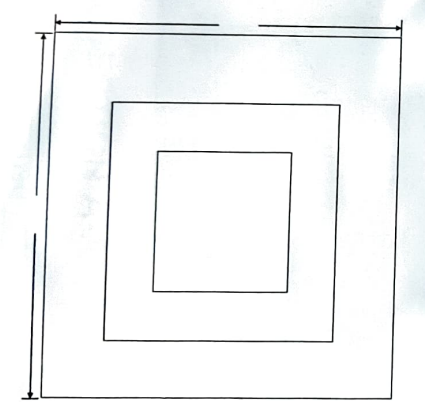
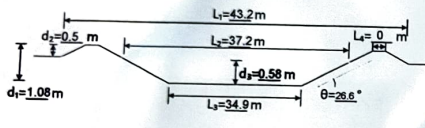
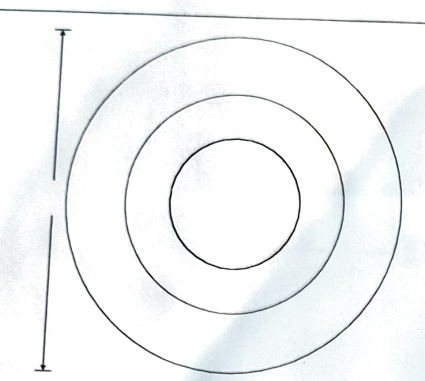

Pond Construction Specification			
Location/Project: Mortlock Malt - Karranadgin			
SIZE	FORM NO	DWG NO	REV
A3			B
SCALE	NOT TO SCALE	SHEET	1 OF 1

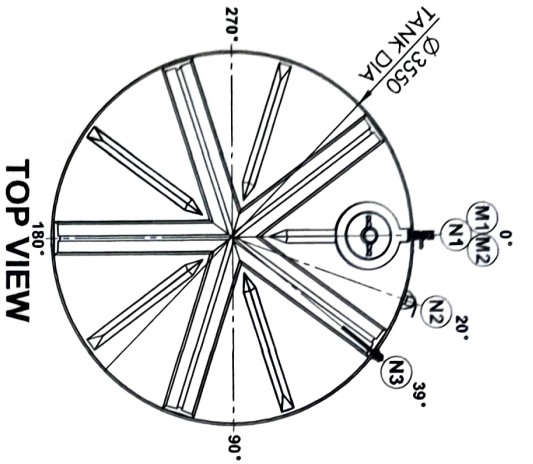

TOP VIEW

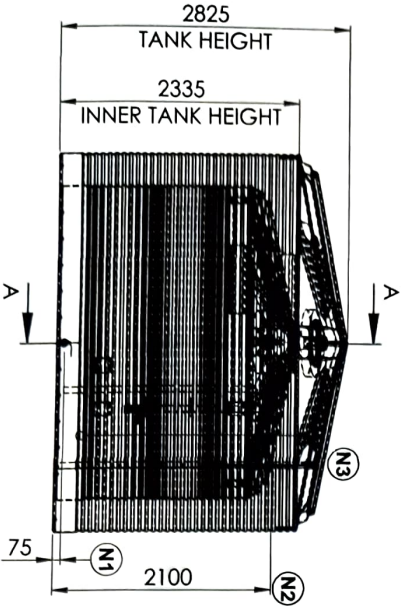

FRONT VIEW

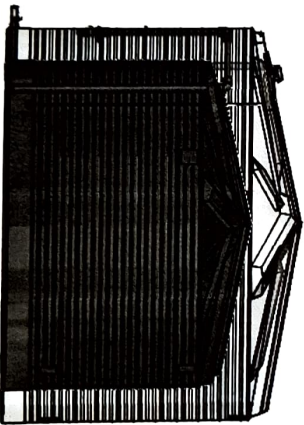

SECTION A-A

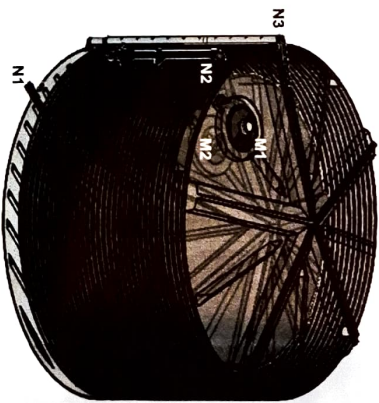

PERSPECTIVE VIEW

NOZZLE	DN	HEIGHT	NOZZLE ANGLE	DESCRIPTION	CONNECTION
N1	50	75	0°	OUTLET	50mm LOW LEVEL OUTLET WITH BALL TAP, ALUMINIUM CAMLOCK & DUST PLUG
N2	50	2100	20°	FILL PIPE	50mm STANDARD FILL PIPE UP TO TANK FLOOR TO PREVENT STATIC BUILD UP
N3	-	-	39°	LIQUIDATOR	LIQUIDATOR 2 LEVEL GAUGE FITTED
M1	455	ROOF	0°	EXTERNAL MANHOLE	VENTED 455mm SCREW LID
M2	355	ROOF	0°	INTERNAL MANHOLE	355mm SCREW LID

13500L BUNDED DIESEL TANK  
95521

FABRICATED BY: \_\_\_\_\_  
 CHECKED BY: \_\_\_\_\_  
 SERIAL NUMBER: \_\_\_\_\_

DATE	23SEP2021	MATERIAL	LUDPE
PRODUCT	95521 - BUNDED DIESEL TANK	SURFACE FINISH	BLACK
PRODUCT CODE	95521 - IT13500 - BLK	WALL THICKNESS	1.25G
DRAWING No	95521	SCALE	NTS



THIS DRAWING IS THE COPYRIGHT OF COERCO. IT CANNOT BE COPIED IN PART OR FULL WITHOUT THE WRITTEN PERMISSION OF COERCO

SHEET 1 OF 1  
 CHKD  
 APVD  
 SHEET SIZE  
**A3**



# DE VREE EQUIPMENT

Sales Pty. Ltd.

51 Winton Road  
PO Box 882  
Joondalup DC WA 6919

Telephone: (08) 9301 0219 Fax: (08) 9301 0229

A.B.N. 92 009 320 816

A.C.N. 009 320 816

## Quotation 121061

To: MORTLOCK MALT  
  
GOOMALLING  
WA 6460

Date: 9/08/2021  
Quote No: 121061  
Page No: 1  
Account No: ROWLES

Your A.B.N. \_\_\_\_\_

Delivery  
Instructions

Part Number	Description	Qty	Price	Unit	GST	Total
1 KF12-400A	KF12 ASPIRATOR COMPLETE 400V Each Comprising: 1 x 131010000 ... KF12 PRE-CLEANER BODY 1 x 131011162 ... FRL10 FAN W/O MOTOR 50HZ 1 x 122000853 ... AIR REGULATOR GR - FRL10 2 x 122000855 ... OKD160 HOPPER W/O GUARD GR 1 x TA2B0114TAI ... MOTOR 1.1KW 2P 400V B4	1	2950.00	Ea	295.00	3245.00
2 131000047	KF12 RC DUST CYCLONE	1	852.50	Ea	85.25	937.75

Thank you for the opportunity to quote.

Totals 380.25 4182.75

Payment Terms - TBA

All goods supplied by DE VREE EQUIPMENT SALES PTY LTD to the remain the property of DE VREE EQUIPMENT SALES PTY LTD until payment has been received in full. The Goods may not be passed on or resold until the full payment has been cleared.

DE VREE EQUIPMENT SALES PTY LTD standard Terms & Conditions of Sale available on request.



Wheatbelt Steel Pty Ltd ABN 45 625 274 688

# TAX INVOICE



Suppliers of  
Premixed Concrete - Minesite & Remote Areas - Sand - Blue Metal

A.B.N. 45 614 655 588

A.C.N. 614 655 588

PO Box 28 Wongan Hills WA 6603  
Lot 10 Jensen Street, Wongan Hills WA 6603  
Lot 307 Tiller Drive, Kellerberrin WA 6410  
27 Gingin Brook Road, Gingin WA 6503  
Tel: (08) 96711111  
Email: admin@wscconcrete.com.au  
Website: www.wscconcrete.com.au

## Tax Invoice

Invoice No: 00004557

Bill To:   
Mortlock Malt

Date	22/04/2021
------	------------

Customer P O.

Terms
Net 30th after EOM

**BANKING DETAILS**  
BSB 036 177 A/C 152 952

QTY	DESCRIPTION	PRICE	INC PRICE	CODE	TOTAL	JOB NUMBER
1	Supply, Delivery and Laying of N25 concrete for Shed Floor and Apron at 6013 Northam-Pithara Rd as per quote.	\$34,499.00	\$37,948.90	GST	\$37,948.90	106078
6	6 hours to complete Earthworks.	\$120.00	\$132.00	GST	\$792.00	

**OVERDUE ACCOUNTS WILL INCUR INTEREST AT 12%.  
WCS CONCRETE PTY LTD USES THE SERVICES OF BCA  
DEBT FOR RECOVERY OF OUTSTANDING MONIES AND  
RESERVE THE RIGHT TO CHARGE FOR THE RECOVERY**  
FFFC

\$35,219.00  
\$3,521.90 GST  
\$38,740.90

<b>Balance Due:</b>	<b>\$38,740.90</b>
---------------------	--------------------



Suppliers of  
Premixed Concrete - Minesite & Remote Areas - Sand - Blue Metal

PO Box 28 Wongan Hills WA 6603  
Lot 10 Jensen Street, Wongan Hills WA 6603  
Lot 307 Tiller Drive, Kellerberrin WA 6410  
27 Gingin Brook Road, Gingin WA 6503  
Tel: (08) 96711111  
Email: admin@wscconcrete.com.au  
Website: www.wscconcrete.com.au



**Wheatbelt Steel Pty Ltd** ABN 45 625 274 688  
 98 Byfield St, NORTHAM WA 6401  
 T 1800 800 909 | F 1800 800 910  
 accounts@wbsgroup.com.au

**TAX INVOICE**  
 102390

**Bill To:**

Mortlock Malt  
 PO Box 351  
 Goomalling  
 WA

6460

**Delivered To:**

Mortlock Malt  
 6013 Northam-Pithara Road  
 Karranadgin  
 WA

6460

Account	Customer Order Ref	Project No.	Invoice Date	Sales Order No.	Payment Terms		
MORTLD02		2861	19-MAR-21	202928	7 Days Date of Invoice		
Item Code	Description	UOM	Order	Shipped	B/Order	Unit Price (exc. GST)	Line Total (exc. GST)
	Payment on Practical Completion 24m x 18m x 5.9m Fully Enclosed Shed Quote ref; 7498 / 1 - Job No. 2861		1.00	1.00	0.00	10,500.00	10,500.00



**Delivery Instructions:**

**EFT Payments:**  
 Bank: **CBA**  
 A/C: **Wheatbelt Steel Pty Ltd**  
 BSB: **065-000**  
 A/C No: **1236 9623**  
 Please quote invoice number  
 Send remittance to remittance@ahrens.com.au.

<b>Sub Total</b>	10,500.00
<b>GST</b>	1,050.00
<b>Total</b>	<b>11,550.00</b>

**Material Test Certificate**  
**AS 1289.6.7.2 Determination of permeability of a soil-Falling head method for a remoulded specimen**

<b>Client:</b>	MORTLOCK MALT	<b>Job Number:</b>	S1008365
<b>Project:</b>	Evap Pond - #6013 NORTHAM-PITHARA RD KARRANADGIN	<b>Issue Number:</b>	1
<b>Report Number:</b>	S1008365-A	<b>Page:</b>	1 of 1
Laboratory testing carried out at Balcatta Laboratory 1 Erindale Rd Balcatta WA 6021			

<b>Sample ID:</b>	Submitted Sample	<b>Date Tested:</b>	25 Feb 2021
<b>Proposed Use:</b>	-	<b>Laboratory Number:</b>	S1008365-A-1
<b>Material Type:</b>	Clay	<b>Depth of Test:</b>	- mm
<b>Moisture content method:</b>	AS 1289.2.1.1	<b>Layer Thickness:</b>	- mm
<b>Sampling Method:</b>	Client	<b>Site Selection Method:</b>	Client

<b>Compaction Data</b>	
Compactive Effort Used	AS 1289.5.2.1 Mod MDD
Maximum Dry Density t/m <sup>3</sup>	2.00
Optimum Moisture Content %	9.5
Required Dry Density Ratio %	95.0
Required Moisture Ratio %	100.0
<b>Compacted Specimen</b>	
Dry Density t/m <sup>3</sup>	1.90
Moisture Content %	9.5
Laboratory Density ratio %	95.0
Laboratory Moisture Ratio %	101.5
Surcharge kPa	3
Sieve Size (mm)	19
Percent material retained on	0
<b>Coefficient of Permeability m/s</b>	1.1E-09

**Remarks**

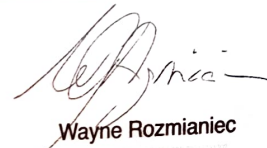
  
**Approved Signatory:** Wayne Rozmianiec  
 Laboratory Manager

**Date:** 5 March 2021





WESTERN

AUSTRALIA

REGISTER NUMBER	
81/DDP68682	
FORMER EDITION	DATE REGISTERED
1	11/8/2011

**RECORD OF CERTIFICATE OF TITLE**  
 UNDER THE TRANSFER OF LAND ACT 1893

VOLUME 2773  
 PAGE 699

The person described in the first schedule is the registered proprietor of an estate in the sample in the land described below subject to the reservations, conditions and depth measurements contained in the original grant (if a grant issued) and to the limitations, interests, encumbrances and modifications shown in the second schedule.

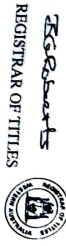

LOT 81 ON DEPOSITED PLAN 68682

LAND DESCRIPTION:

**REGISTERED PROPRIETOR:**  
 (FIRST SCHEDULE)  
**REX HENRY ROWLES**  
**SIMONE LOUISA JANE ROWLES**  
**BOTH OF LOT 81 NORTHAM-PTHARA ROAD, KARRANADGIN**  
**AS JOINT TENANTS**

(T1725160) REGISTERED 5 SEPTEMBER 2011

**LIMITATIONS, INTERESTS, ENCUMBRANCES AND NOTIFICATIONS:**  
 (SECOND SCHEDULE)

- \*L725161 MORTGAGE TO AUSTRALIA & NEW ZEALAND BANKING GROUP LTD REGISTERED 5.9.2011.

**Warning:** A current search of the sketch of the land should be obtained where detail of position, dimensions or area of the lot is required. Any entries preceded by an asterisk may not appear on the current edition of the duplicate certificate of title. Lot as described in the land description may be a lot or location.

-----END OF CERTIFICATE OF TITLE-----

**STATEMENTS:**

The statements set out below are not intended to be nor should they be relied on as substitutes for inspection of the land and the relevant documents or for local government, legal, surveying or other professional advice.

**SKETCH OF LAND:** DP68682 [SHEET 1].  
**PREVIOUS TITLE:** 2774-870.  
**PROPERTY STREET ADDRESS:** NO STREET ADDRESS INFORMATION AVAILABLE.  
**LOCAL GOVERNMENT AREA:** SHIRE OF GOOMALLING.

**NOTE 1:** DUPLICATE CERTIFICATE OF TITLE NOT ISSUED AS REQUESTED BY DEALING L725161



# 50,000LTR FLAT WALLED POLY WATER TANK

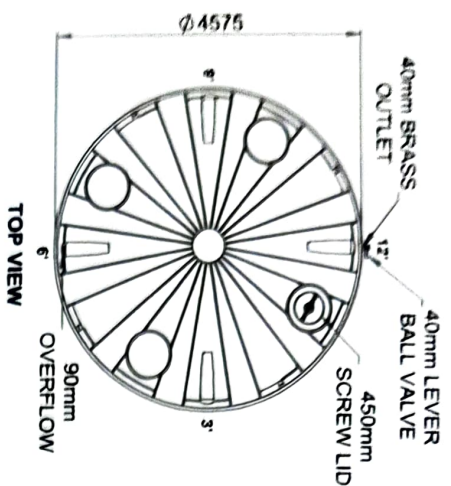

**INSTALLATION:**  
TANKS ARE TO BE INSTALLED ON A WELL COMPACTED, LEVELLED EARTH PAD. FREE FROM SHARP OR LOCALISED HARD STONES/OBJECTS THAT COULD DAMAGE THE TANK BASE. THE ROOF OF THIS TANK IS INTENDED ONLY TO COVER AND IS NOT TO BE TRAFFICABLE ROOF.

**MATERIAL:**  
LDPE MATERIAL DESIGNED SPECIFICALLY FOR ROTATIONAL MouldING APPLICATIONS DELIVERING A HIGH ESCR, CHEMICAL RESISTANCE STIFFNESS AND TOUGHNESS WHICH IS UV STABILISED TO PROVIDE PROLONGED OUTDOOR PROTECTION IN HARSH AUSTRALIAN CONDITIONS.

**STANDARDS:**  
ALL TANKS BY COERCO ARE MANUFACTURED IN GUIDANCE WITH AUSTRALIAN STANDARD AS4766 AND ARE STRUCTURALLY ENGINEERED TO CONFORM TO CYCLONIC AREAS AND STRESS ANALYSIS TESTING REQUIREMENTS.

**DIMENSIONS:**  
DIMENSIONS MAY VARY SLIGHTLY DUE TO THE SHRINKAGE NATURE OF POLYETHYLENE.

**NOTE:** THIS DRAWING DETAILS COERCO'S STANDARD WATER TANK FITOUT.

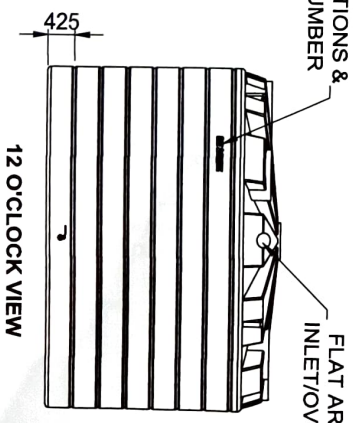
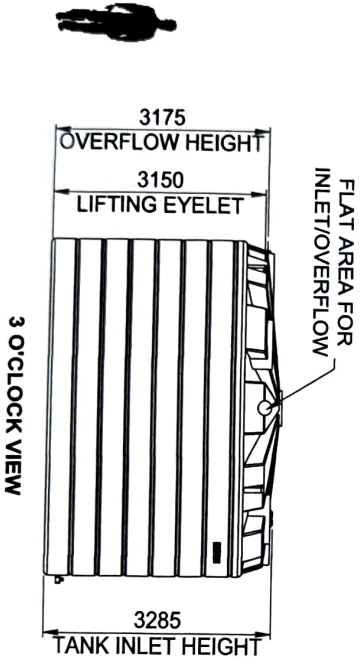
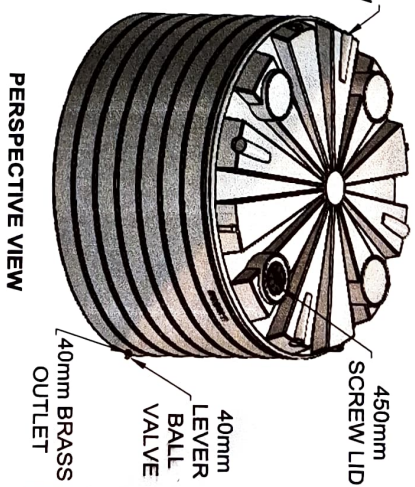

DATE	01/03/2019	MATERIAL	LOW DENSITY POLYETHYLENE	REVISION	1	GT	30/06/2020	ADDED TANK INLET HEIGHT	SHEET 1 OF 1
PRODUCT CODE	JRRS0000	SURFACE FINISH	POLISHED	REVISION	0	GT	01/03/2019	ORIGINAL CAD DRAWING ISSUED	CHKD
DRAWING No	C-JRRS0000-001	WALL THICKNESS	-	REV	BY	DATE	DESCRIPTION	APVD	SHEET A3
<p>NOT TO SCALE</p> <p>THIS DRAWING IS THE COPYRIGHT OF COERCO. IT CANNOT BE COPIED IN PART OR FULL WITHOUT THE WRITTEN PERMISSION OF COERCO</p>									