



## Application for Licence Amendment

### Part V Division 3 of the *Environmental Protection Act 1986*

---

<b>Licence Number</b>	L6068/1991/9
<b>Licence Holder</b>	Water Corporation
<b>ACN</b>	28 003 434 917
<b>File Number</b>	DWERVT6976~1
<b>Premises</b>	Wundowie Wastewater Treatment Plant (WWTP) Lots 28194, 27737 and 28525 on Plan 207683 and Lot 28438 on Plan 175669, Coates Road, Wundowie As defined by the Premises maps attached to the Revised Licence
<b>Date of Report</b>	28 April 2021
<b>Proposed Decision</b>	Revised licence granted

**JARROD ABRAHAMS**  
**MANAGER WASTE INDUSTRIES**  
an officer delegated under section 20 of  
the *Environmental Protection Act 1986* (WA)

## Table of Contents

<b>1. Decision summary</b>	<b>1</b>
<b>2. Scope of assessment</b>	<b>1</b>
2.1 Regulatory framework	1
2.2 Amendment/Application summary	1
<b>3. Consultation</b>	<b>1</b>
<b>4. Conclusion</b>	<b>2</b>
4.1 Summary of amendments	2
<b>Appendix 1: Summary of Licence Holder’s comments on draft amendment</b>	<b>4</b>

# 1. Decision summary

The Delegated Officer has determined to make amendments to Licence L6068/1991/9. The amendments are administrative in nature therefore they do not alter the risk profile of the Premises, providing that activities, emissions and receptors as stated in existing approvals remain unchanged.

This Amendment Report documents the amendments made pursuant to section 59 and 59(B) of the *Environmental Protection Act 1986* (EP Act).

The decision report for the existing licence will remain on the department's website for future reference and will act as a record of the department's decision making.

# 2. Scope of assessment

## 2.1 Regulatory framework

In amending the licence, the department has considered and given due regard to its Regulatory Framework and relevant policy documents which are available at <https://dwer.wa.gov.au/regulatory-documents>.

## 2.2 Amendment summary

Licence L6068/1991/9 is held by Water Corporation (Licence Holder) for the Wundowie Waste Water Treatment Plant (the Premises), located at Lots 28194, 27737 and 28525 on Plan 207683 and Lot 28438 on Plan 175669, Coates Road, Wundowie.

On 23 December 2020, the Licence Holder submitted an application to the department to amend Licence L6068/1991/9 under section 59B of the *Environmental Protection Act 1986* (EP Act).

The amendment is limited to altering the prescribed premises boundary to excise an area in which a chlorinator is proposed to be constructed. The chlorinator is related to the Shire reuse of the treated water and the chlorine dosing point will be located after the storage dam (refer to Figure 1 below). As such, the chlorinator is considered to be a related activity to the primary activity of sewage treatment but not part of the primary activity in and of itself. In this regard, the installation and operation of the chlorine dosing unit outside of the boundary of a prescribed premises is not required to be subject to the licensing and works approval provisions of the *Environmental Protection Act 1986*.

A schematic of the proposed chlorine solution dose point is shown in **Figure 6-2**.

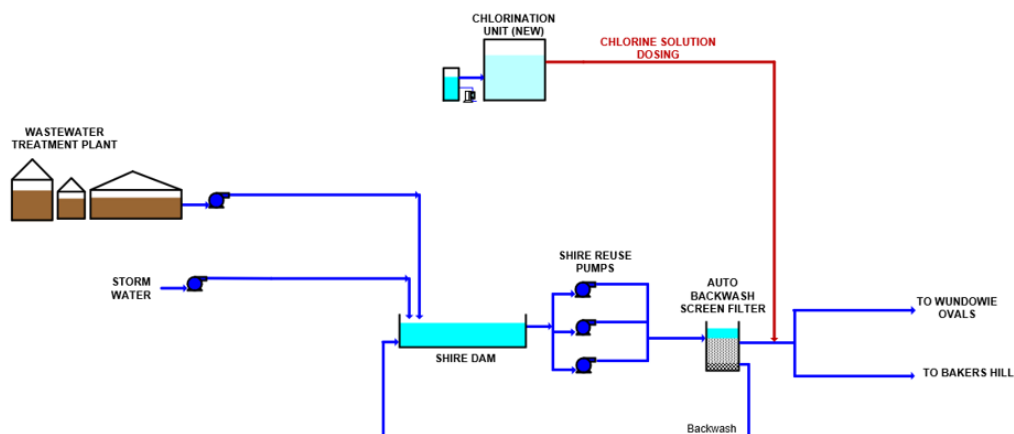

**Figure 1. Location of chlorinator**

In amending the licence, the CEO has also:

- updated the format and appearance of the licence;
- revised licence condition numbers, and removed any redundant conditions and realigned condition numbers for numerical consistency; and
- corrected clerical mistakes and unintentional errors.

### 3. Consultation

The Licence Holder was provided with the draft Amendment Report on 29/03/2021. Comments received from the Licence Holder on 19/04/2021 have been considered by the Delegated Officer as detailed in Appendix 1.

### 4. Conclusion

Based on the assessment in this Amendment Report, the Delegated Officer has determined that an amended licence will be granted, subject to conditions commensurate with the determined controls and necessary for administration and reporting requirements.

#### 4.1 Summary of amendments

Table 1 below provides a summary of the proposed amendments and will act as a record of implemented changes. All proposed changes have been incorporated into the Revised licence as part of the amendment process.

**Table 1: Summary of licence amendments**

Existing condition	Condition summary	Revised licence condition	Conversion notes
Preamble		NA	Explanatory statements removed
Definitions	Definitions	NA	Definitions moved to the end of the Licence – Table 3
W1	Treatment pond	Condition 1	Licence condition retained from previous licence.
W2	Monitoring Device	Condition 2	Licence condition retained from previous licence.
W3	Sampling requirements	Condition 3	Licence condition retained from previous licence – updated to a tabular format
W4(a) & (b)	Methodology	NA	Explanatory statements removed. Requirements retained in Table 1.
W5(a), (b) & (c)	Contamination load calculations	Condition 4	Licence condition retained from previous licence.
S1(a)	Solid waste disposal	Condition 5	Licence condition retained from previous licence.

S1(b)	Sewage sludge temporary storage	Condition 6	Licence condition retained from previous licence.
S1(c)	Disposal of sludge and biosolids	Condition 7	Licence condition retained from previous licence.
G1	Monitoring and reporting	Condition 8	Licence condition retained from previous licence but changed to a new format
G2	Annual audit compliance reporting	Condition 9	Licence condition retained from previous licence. Standard licence condition
G3	Storage and handling	NA	Previous licence condition relating to the storage and handling of dangerous goods has been removed as it is related to a code of practice which is not administered by DWER.
NA	Records	Condition 10	Standard licence condition
NA	Records	Condition 11	Standard licence condition
NA	Records	Condition 12	Standard licence condition
Schedule 1	Premises map	Schedule 1 Figures 1 and 2	Figures 1 and 2 updated aerial image.
Schedule 2	N/A	Schedule 2 premises boundary coordinates	Revised to current licensing format.
NA		Schedule 3	Revised to current licensing format. AACR form is to be obtained from the department's website

## Appendix 1: Summary of Licence Holder's comments on draft amendment (if required)

Condition	Summary of Licence Holder's comment	Department's response
4	<p>Propose removing this condition.</p> <p>Reasoning: The BOD5 is used to indicate the effects of sewage and other organic wastes on dissolved oxygen in surface waters. Given that all treated wastewater is sent to re-use the 20mg/L limit is not required.</p> <p>Note: filtered-BOD5 will continue to be reported in the AER.</p>	Accepted – old condition 4 removed and condition 3 modified.
9(a)	Request DWER provide timeframe for notify that equipment is offline (i.e. other Licences have 48 or 72 hours in the non-annual reporting condition)	Accepted – condition modified with following: a) inform the CEO 48 to 72 hours prior to taking a treatment pond offline for maintenance works.
14 and 15	Propose replacing the term books with records i.e. The licence holder must maintain accurate records, including information, reports and data required by this licence	Accepted – conditions updated and numbering revised (relates to condition 11 and 12 in the final amendment).
5, 6 and 7	<p>Proposed merging Conditions 5, 6 and 7 and proposed new wording for better clarity:</p> <p>The licence holder shall determine the 3 monthly loads of each contaminant in the treated wastewater discharged from the premises (excepted pH and bacteria) using flow-weighted data. The loads shall be based on the treated wastewater discharge rate and the concentration as measured in accordance with Conditions 2. 3-monthly and annual average loads of the contaminates shall be reported in the Annual Environmental report in kilograms per day.</p>	Accepted – all merged to create a revised condition 4.
15	Correct typo – condition refers to Condition 17, this should be Condition 14.	Corrected typo with reference to condition 11.