



Works approval number	W6769/2023/1
Works approval holder	Onslow Iron Pty Ltd
ACN	649 012 395
Registered business address	20 Walters Drive OSBORNE PARK WA 6017
DWER file number	DER2022/000623
Duration	29/05/2023 to 28/05/2028
Date of issue	25/05/2023
Date of amendment	3/09/2024
Premises details	West Pilbara Iron Ore Project M08/480, M08/484, G08/88, L08/67, L08/68, L08/69 and L08/181 CANE WA 6710

Prescribed premises category description (Schedule 1, <i>Environmental Protection Regulations 1987</i>)	Assessed production / design capacity
Category 5: Processing or beneficiation of metallic or non-metallic ore	45,000,000 tonnes per annual period
Category 12: Screening, etc. of material	1,700,000 tonnes per annual period
Category 52: Electric power generation	40 MW
Category 54: Sewage facility	223 m ³ /day of treated effluent, plus 137 m ³ /day of RO reject
Category 57: Used tyre storage	11,000 tyres
Category 64: Class II putrescible landfill site	9,000 tonnes per annual period
Category 73: Bulk storage of chemicals, etc.	3,700 m ³ in aggregate
Category 77: Concrete batching or cement products manufacturing	650,000 tonnes per annual year

This works approval is granted to the works approval holder, subject to the attached conditions, on 3 September 2024, by:

Alana Kidd

MANAGER, GREEN ENERGY

Officer delegated under section 20 of the *Environmental Protection Act 1986*

Works approval history

Reference number	Date	Summary of changes
W6769/2023/1	25/05/2023	Works approval granted for categories 5, 12, 52, 54, 57, 64, 73 and 77.
W6769/2023/1	08/04/2024	Administrative amendment to extend TLO from 180 days to 280 days for the operation of Category 54 Infrastructure and associated authorised discharges at the Accommodation Resort Wastewater Treatment Plant (WWTP).
W6769/2023/1	03/09/2024	<p>Applicant initiated works approval amendment for the</p> <ul style="list-style-type: none"> - relocation of wastewater (WWTP) and effluent spray field at Upper Cane NPI - increase throughput and design capacity of Upper Cane WWTP to 5.25 m³/day - expand Upper Cane treated effluent irrigation spray field to minimum size of 0.78 ha - include 20m³/day RO Plant at Upper Cane and disposal of RO brine at Upper Cane spray field as combined discharge with treated effluent. <ul style="list-style-type: none"> • contingency to use RO brine for dust suppression in disturbed areas.

Interpretation

In this works approval:

- (a) the words 'including', 'includes' and 'include' in conditions mean "including but not limited to", and similar, as appropriate;
- (b) where any word or phrase is given a defined meaning, any other part of speech or other grammatical form of that word or phrase has a corresponding meaning;
- (c) where tables are used in a condition, each row in a table constitutes a separate condition;
- (d) any reference to an Australian or other standard, guideline, or code of practice in this works approval:
 - (i) if dated, refers to that particular version; and
 - (ii) if not dated, refers to the latest version and therefore may be subject to change over time;
- (e) unless specified otherwise, any reference to a section of an Act refers to that section of the EP Act; and
- (f) recommend just checking what the factors were and where - so we don't allow them to use RO water and then kill priority veg for example;
- (g) unless specified otherwise, all definitions are in accordance with the EP Act.

NOTE: This works approval requires specific conditions to be met but does not provide any implied authorisation for other emissions, discharges, or activities not specified in this works approval.

Works approval conditions

The works approval holder must ensure that the following conditions are complied with:

Construction phase

Infrastructure and equipment

1. The works approval holder must:
 - a) construct and/or install the infrastructure and/or equipment;
 - b) in accordance with the corresponding design and construction / installation requirements; and
 - c) at the corresponding infrastructure location, as set out in Table 1.

Table 1: Design and construction / installation requirements

Item no.	Infrastructure	Design and construction / installation requirements	Infrastructure location
Category 5			
1	CPF consisting of:		
	CPF Crushing and Screening Plant	Concrete hardstand at the CPF beneath the primary and secondary crushers and conveyor transfer points	At the location shown in Schedule 1, Figure 2 labelled 'Crushing and Processing Plant' and 'Primary Crushers'
		Concrete sumps to collect wash down water from conveyors	
		<p>Total design capacity to not exceed 45,000,000 tpa for all processing circuits, consisting of:</p> <p><u>Primary processing:</u></p> <ul style="list-style-type: none"> • Three Metso C160 jaw crusher or equivalent with apron feeder, scalping / grizzly screen and rock breaker • Three Primary conveyor • Three combined road train and dump truck tip pocket • In loading conveyor <p><u>Secondary processing:</u></p> <ul style="list-style-type: none"> • Up to six cone crushers • Up to six double deck vibrating screens • Up to six Secondary Surge Bins • Six Feed conveyors 	As shown in Schedule 1, Figures 3 to 5

Item no.	Infrastructure	Design and construction / installation requirements	Infrastructure location
		<u>Tertiary processing:</u> <ul style="list-style-type: none"> • Up to six cone crushers • Up to six double deck vibrating screens • Recirculation conveyors • Product conveyors • Product transfer conveyors 	
	Stockyard and Stackers	<ul style="list-style-type: none"> • Stockyard and Feed Conveyors • Stacking Sample Station Feed Conveyor • Product Stacker Conveyors • Product Stackers 	At the location shown in Schedule 1, Figure 2 labelled 'Stockyard' As shown in Schedule 1, Figure 6
	Reclaim and Truck Load Out	<ul style="list-style-type: none"> • Bucket Wheel Reclaimer • Truck Load out Conveyor • Truck Load out Bin 	
	Dust controls	<ul style="list-style-type: none"> • Sprays systems (droplet and fogging) located at the ROM bin and transfer points throughout the crushing and screening circuit • Skirts on conveyors • Automated water cannons installed at the stockyard area 	As shown in Schedule 1, Figures 3 to 6 labelled as 'Water Sprays'
	Stormwater management	<ul style="list-style-type: none"> • Stormwater diversion designed to direct uncontaminated stormwater away from processing and material stockpile areas into earthen sedimentation ponds • Unlined sedimentation ponds constructed in and around the CPF to capture any sediment laden surface water runoff from the processing and stockyard area • Sedimentation ponds designed for a 1-year ARI, 1-hour rainfall event 	Not shown
Crushing and screening plant at the ROM			
2	Crushing and screening plant	2-stage mobile crushing and screening plant not exceeding 7,000,000 tpa design capacity, consisting of: <ul style="list-style-type: none"> • Jaw crusher 	At the location shown in Schedule 1, Figure 2, labelled 'ROM'

Item no.	Infrastructure	Design and construction / installation requirements	Infrastructure location
		<ul style="list-style-type: none"> • Cone crusher • Horizontal screener • Mounted mobile tracked conveyor <p><u>Dust controls:</u></p> <ul style="list-style-type: none"> • Hose and spray bars fitted on main and auxiliary conveyors of jaw crusher • Dust suppression fitted at cone inlet and outlet • Cone crusher conveyor fitted with hose and spray bars, full length skirting to head drum • Transfer conveyor of horizontal screener fully skirted • Dust covers running full conveyor and a head chute with rubber sock on incline conveyor 	
Category 12			
3	Mobile crushing and screening plant	<p>2-stage mobile crushing and screening plant not exceeding 1,700,000 tpa throughput, consisting of:</p> <ul style="list-style-type: none"> • Jaw crusher • Cone crusher • Horizontal screener • Mounted mobile tracked conveyor <p><u>Dust controls:</u></p> <ul style="list-style-type: none"> • Hose and spray bars fitted on main and auxiliary conveyors of jaw crusher • Dust suppression fitted at cone inlet and outlet • Cone crusher conveyor fitted with hose and spray bars, full length skirting to head drum • Transfer conveyor of horizontal screener fully skirted • Dust covers running full conveyor, and a head chute with rubber sock on incline conveyor 	Mobile across the two locations shown in Schedule 1, Figure 2 labelled 'Mobile Crushing and Screening Plant (indicative Location)'
Category 52			
4	Power station	<ul style="list-style-type: none"> • 12 x 3.3 MW reciprocating gas powered generators 	At the location shown in Schedule

Item no.	Infrastructure	Design and construction / installation requirements	Infrastructure location
		<ul style="list-style-type: none"> • Generators fitted with a 2-stage intercooler and exhausts coupled with a silencer • Gas generator stacks (12) minimum height of 8 m above ground level • Each generator will include mufflers and bafflers • Generators installed within a purpose-built engine hall and bunded • Power station engine hall erected on concrete pad • Designed with a purpose-built drainage system, with potentially contaminated runoff draining to a local sump 	<p>1, Figure 2 labelled 'Power station'</p> <p>As shown in Schedule 1, Figure 7</p>
Category 54			
5	Accommodation Resort WWTP and Irrigation Spray Field	<p><u>WWTP:</u></p> <ul style="list-style-type: none"> • 200 m³/day MBR containerised modular system • Installed on either concrete or compact ground • Installed with systems to monitor tank volume levels • Flow meters installed • Components of the WWTP fitted with alarms to warn of high-water levels in the tank or if a pump failure occurs • Aerobic/MBR tank fitted with an emergency overflow which discharges to the screened influent lift station • Operating freeboard maintained on the treated effluent tank to allow TDS correction if required • Treat up to 130 m³/day of RO reject • Be able to treat sewage to the following output emissions standards: <p>BOD <20 mg/L</p> <p>TSS <30 mg/L</p> <p>Total Nitrogen <20 mg/L</p>	<p>At the location shown in Schedule 1, Figure 8 labelled 'Waste Water Treatment Plant' and 'Irrigation Spray Field'</p> <p>As shown in Schedule 1, Figure 9</p>

Item no.	Infrastructure	Design and construction / installation requirements	Infrastructure location
		<p>Total Phosphorus <3 mg/L</p> <p><i>E.coli</i> <1,000 cfu/100 mL</p> <p>Residual free chlorine 0.2 – 2.0 mg/L</p> <p>pH 6.5 – 8.5 pH units</p> <p><u>Irrigation Spray Field</u> to consist of:</p> <ul style="list-style-type: none"> • Above ground sprinklers • Fencing with safety signage • Sized up to 14.45 ha 	
6	CPF WWTP and Irrigation Spray Field	<p><u>WWTP</u>:</p> <ul style="list-style-type: none"> • 15 m³/day sequence batch reactor system • Installed on either concrete or compact ground • Installed with systems to monitor tank volume levels • Flow meters installed • Be able to treat sewage to the following output emissions standards: <p>BOD <20 mg/L</p> <p>TSS <30 mg/L</p> <p>Total Nitrogen <30 mg/L</p> <p>Total Phosphorus <8 mg/L</p> <p><i>E.coli</i> <1,000 cfu/100 mL</p> <p>Residual free chlorine 0.2 – 2.0 mg/L</p> <p>pH 6.5 – 8.5 pH units</p> <p><u>Irrigation Spray Field</u> to consist of:</p> <ul style="list-style-type: none"> • Above ground sprinklers • Fencing with safety signage • Sized up to 2.19 ha plus a 5 m spray drift buffer 	<p>At the location shown in Schedule 1, Figure 2 labelled 'Waste Water Treatment Plant' and 'Irrigation Spray Field'</p> <p>As shown in Schedule 1, Figure 10</p>
7	Upper Cane WWTP, and	<u>WWTP</u> :	At the location

Item no.	Infrastructure	Design and construction / installation requirements	Infrastructure location												
	Irrigation Spray Field	<ul style="list-style-type: none"> • 5.25 m³/day below ground submerged aerated filter system • Installed with systems to monitor tank volume levels • Flow meters installed • RO reject will be co-disposed with treated effluent from the WWTP. Up to 6.4 m³/day of RO reject co-disposed • Be able to treat sewage to the following output emissions standards: <table style="margin-left: 20px; border: none;"> <tr> <td>BOD</td> <td><20 mg/L</td> </tr> <tr> <td>TSS</td> <td><30 mg/L</td> </tr> <tr> <td>Total Nitrogen</td> <td><30 mg/L</td> </tr> <tr> <td>Total Phosphorus</td> <td><8 mg/L</td> </tr> <tr> <td><i>E.coli</i></td> <td><1,000 cfu/100 mL</td> </tr> <tr> <td>pH</td> <td>6.5 – 8.5 pH units</td> </tr> </table> <p><u>Irrigation Spray Field</u> to consist of:</p> <ul style="list-style-type: none"> • Above ground sprinklers • Fencing with safety signage • Minimum 0.78 ha plus a 5 m spray drift buffer 	BOD	<20 mg/L	TSS	<30 mg/L	Total Nitrogen	<30 mg/L	Total Phosphorus	<8 mg/L	<i>E.coli</i>	<1,000 cfu/100 mL	pH	6.5 – 8.5 pH units	<p>shown in Schedule 1, Figure 11 labelled 'Waste Water Treatment Plant' and 'Irrigation Spray Field'</p> <p>As shown in Schedule 1, Figure 12 and 13</p>
BOD	<20 mg/L														
TSS	<30 mg/L														
Total Nitrogen	<30 mg/L														
Total Phosphorus	<8 mg/L														
<i>E.coli</i>	<1,000 cfu/100 mL														
pH	6.5 – 8.5 pH units														
Category 57															
8	Used tyre storage facility	<ul style="list-style-type: none"> • Concrete or compacted dirt pad for tyre storage • Cell sized in accordance with <i>DFES 2020</i> to store up to 11,000 used tyres • Fire suppression system in accordance with <i>DFES 2020</i> • Designed so that stormwater and firefighting runoff are directed into sedimentation ponds to prevent uncontrolled discharge 	At the location shown in Schedule 1, Figure 2 labelled 'Used Tyre Storage'												
Category 64															
9	Landfill	<ul style="list-style-type: none"> • Signage for the landfill, including 	At the location												

Item no.	Infrastructure	Design and construction / installation requirements	Infrastructure location
		<p>signage within the landfill to designate specific areas</p> <ul style="list-style-type: none"> • Design capacity of 9000 tpa • Windrows of excavated material around three sides of the cells to prevent surface water flows from entering the landfill • All landfill cells / trenches that are within the WRL are to be 100 m from the planned WRL edge • Putrescible trenches approximately 30 m long, 5 m wide with a maximum depth of 4 m • Each putrescible trench to have an egress ramp • Putrescible trenches fenced (or a suitable barrier used) and have an access gate 	<p>shown in Schedule 1, Figure 2 labelled 'Proposed Landfill/ Bioremediation Facility'</p>
Category 73			
10	Bulk Fuel Facilities	<p><u>CPF Bulk Fuel Facility:</u></p> <ul style="list-style-type: none"> • 1 x 200,000 L master tank • 4 x 200,000 L slave tanks • 1 x 12,000 L day tank • Horizontal, double walled tanks with interstitial leakage monitoring probes system fitted and fitted with overflow alarms and mechanical overflow protection • Above ground steel pipework for fuel transfer and delivery • Bollards or earthen bunds for pipework protection where required • Storage area impermeable and graded to a collection sump within secondary containment bund • Up to three fuel tanker loading gantries, located on impervious apron 	<p>At the location shown in Schedule 1, Figure 2 labelled 'Fuel Storage Facility'</p> <p>As shown in Schedule 1, Figure 14</p>

Item no.	Infrastructure	Design and construction / installation requirements	Infrastructure location
		<p><u>Upper Cane Bulk Fuel Farm:</u></p> <ul style="list-style-type: none"> • 1 x 200,000 L master double wall tank • 2 x 200,000 L slave double wall tanks • 1 x 1,000 L day tank located at master tank cowl with overfill protection valve • Concrete bund at fill points 	<p>At the location shown in Schedule 1, Figure 11 labelled 'Refueling Area'</p> <p>As shown in Schedule 1, Figure 15</p>
Category 77			
11	Concrete batching plant	<p>Transcrete mobile silo system consisting of:</p> <ul style="list-style-type: none"> • Enclosed Augers • Feed Hoppers fitted with level indicators • Concrete Storage Silos • Silos equipped with venting filters and overflow protection • Concrete Transfer Valves 	<p>At the location shown in Schedule 1, Figure 2 labelled 'Concrete Batch Plant'</p> <p>As shown in Schedule 1, Figure 16</p>

Compliance reporting

2. The works approval holder must within 30 calendar days of an item of infrastructure or equipment (or circuit of the CPF) required by condition 1 being constructed and/or installed:
 - a) undertake an audit of their compliance with the requirements of condition 1; and
 - b) prepare and submit to the CEO an Environmental Compliance Report on that compliance.
3. The Environmental Compliance Report required by condition 2, must include as a minimum the following:
 - a) certification by a suitably qualified engineer that the items of infrastructure or component(s) thereof, as specified in condition 1, have been constructed in accordance with the relevant requirements specified in condition 1;
 - b) as constructed plans and a detailed site plan for each item of infrastructure or component of infrastructure specified in condition 1; and
 - c) be signed by a person authorised to represent the works approval holder and contains the printed name and position of that person.

Environmental commissioning phase

Environmental commissioning requirements and emission limits

4. The works approval holder may only commence environmental commissioning of an item of infrastructure listed in condition 5 once the Environmental Compliance Report has been submitted for that item of infrastructure in accordance with condition 2 of this works approval.
5. Any environmental commissioning activities undertaken for an item of infrastructure specified in Table 2 may only be carried out:
 - a) in accordance with the corresponding commissioning requirements; and
 - b) for the corresponding authorised commissioning duration.

Table 2: Environmental commissioning requirements

Infrastructure	Commissioning requirements	Authorised commissioning duration									
CPF including: Crushing and Screening Plant Stockyard and Stackers infrastructure Reclaim and Truck Load Out infrastructure	Environmental commissioning activities consisting of: <ul style="list-style-type: none"> ○ Stage 2: Pre-commissioning ○ Stage 3: No load commissioning ○ Stage 4: Load commissioning <ul style="list-style-type: none"> ● Dust suppression sprays / cannons as specified in condition 1 to be tested to ensure functionality ● Dust suppression water applied to operational areas that have the potential to generate dust 	For a period not exceeding 365 calendar days from the submission date of each circuit as required by condition 2									
Crushing and screening plant at the ROM pad	<ul style="list-style-type: none"> ● Components tested and checked, in accordance with manufacturing and operating specifications ● Dust suppression sprays as specified in condition 1 to be tested to ensure functionality 	For a period not exceeding 7 calendar days in aggregate									
Mobile crushing and screening plant											
Power station	<ul style="list-style-type: none"> ● Standard mechanical completion checks ● Performance in accordance with manufacturer's specifications ● Expected output emissions: <table border="1" style="width: 100%; border-collapse: collapse;"> <thead> <tr> <th style="text-align: left;">Emission Component</th> <th style="text-align: center;">Emission limit (1 engine) full load Mg/Nm³ @ 5% O₂</th> <th style="text-align: center;">Emission limit (1 engine) full load tonne/yr</th> </tr> </thead> <tbody> <tr> <td>NO_x</td> <td style="text-align: center;">500</td> <td style="text-align: center;">3.35</td> </tr> <tr> <td>CO</td> <td style="text-align: center;">1,500</td> <td style="text-align: center;">10.04</td> </tr> </tbody> </table>	Emission Component	Emission limit (1 engine) full load Mg/Nm ³ @ 5% O ₂	Emission limit (1 engine) full load tonne/yr	NO _x	500	3.35	CO	1,500	10.04	For a period not exceeding 120 calendar days in aggregate
Emission Component	Emission limit (1 engine) full load Mg/Nm ³ @ 5% O ₂	Emission limit (1 engine) full load tonne/yr									
NO _x	500	3.35									
CO	1,500	10.04									

Infrastructure	Commissioning requirements				Authorised commissioning duration
	SO ₂	13	0.17		
	Particulates	10	0.067		
WWTPs	<ul style="list-style-type: none"> Volumetric flow meters are maintained on each WWTP outlet to the irrigation spray fields All WWTP units maintained and operated in accordance with the requirements as specified in condition 1 				For a period not exceeding 90 calendar days for each WWTP
Irrigation Spray Fields	<ul style="list-style-type: none"> Maintained and operated in accordance with the requirements as specified in condition 1 Irrigation is managed to prevent ponding and pooling of effluent on the ground surface of the irrigation spray field 				
Bulk Fuel Facilities	<ul style="list-style-type: none"> Performance in accordance with manufacturer specifications. Leak and Integrity testing in accordance with manufacture specifications. 				For a period not exceeding 90 calendar days in aggregate
Concrete batch plant	<ul style="list-style-type: none"> Components of the concrete batch plant tested and checked it is in a serviceable condition Dust suppressions sprays tested to ensure functionality 				For a period not exceeding 60 calendar days in aggregate

6. During environmental commissioning, the works approval holder must ensure that the emission(s) specified in Table 3, are discharged only from the corresponding discharge point(s) and only at the corresponding discharge point location(s).

Table 3: Authorised discharge points during commissioning

Emission	Discharge point	Discharge point location
Gas generator exhausts	12 stacks with a minimum height of 8 m above ground level	As shown in Schedule 1, Figure 7
Blended effluent (treated effluent + RO reject)	Irrigation Spray Field – Accommodation Resort WWTP	As shown in Schedule 1, Figure 8 'Irrigation Spray Field'
Blended effluent (treated effluent + RO reject)	Irrigation Spray Field – Upper Cane	As shown in Schedule 1, Figure 11 'Irrigation Spray Field'
Treated effluent	CPF Irrigation Spray Filed	As shown in Schedule 1, Figure 2

7. During environmental commissioning, the works approval holder must ensure that the emissions from the discharge point listed in Table 4 do not exceed the

corresponding limit when monitored in accordance with condition 8.

Table 4: Emission and discharge limits during environmental commissioning

Discharge point	Parameter	Limit
Accommodation Resort Irrigation Spray Field	TDS	3,500 mg/L
Upper Cane Irrigation Spray Field	TDS	3,500 mg/L

Monitoring during environmental commissioning

8. The works approval holder must monitor emissions during environmental commissioning in accordance with Table 5.

Table 5: Emissions and discharge monitoring during environmental commissioning

Discharge point	Monitoring location	Parameter	Frequency	Averaging Period	Unit	Method
12 x Exhaust stacks	Exhaust stacks	Volumetric flow rate	At least once during commissioning ²	Minimum 30 minutes	m ³ /s	USEPA Method 2
		Oxides of Nitrogen (NO _x)			mg/m ³ and g/s ¹	USEPA Method 7E
		Carbon monoxide (CO)			mg/m ³ and g/s ¹	USEPA Method 10
		Sulfur dioxide (SO ₂)			mg/m ³ and g/s ¹	USEPA Method 6 or 6C
		Particulates			mg/m ³ and g/s ¹	USEPA Method 17
Irrigation Spray Fields As shown in Schedule 1, Figures 2, 8 and 11	Flow meter at each WWTP	Volume discharged to irrigation spray field	Continuous	Cumulative daily	kL/day	Flow meter device
	Flow meter at RO plant	Volume of RO reject to treated effluent tank				
	Final treatment tank sampling tap at: Accommodation Resort WWTP CPF WWTP Upper Cane WWTP	BOD	Weekly	Spot sample	mg/L	AS/NZS 5667.1 AS/NZS 5667.10
		TSS			mg/L	
		Total Nitrogen			mg/L	
		Total Phosphorus			mg/L	
		<i>E.coli</i>			cfu/100 mL	
		pH ³	Continuous	N/A	pH units	
	Final treatment tank sampling tap at: Accommodation Resort WWTP CPF WWTP	Residual free chlorine ³	Continuous	N/A	mg/L	
	Final treatment tank sampling tap at: Accommodation Resort WWTP Upper Cane WWTP	TDS	Weekly	Spot sample	mg/L	

Note 1: All units are referenced to STP dry and 5% O₂.

Note 2: Monitoring shall be undertaken to reflect phased start up installed capacity of 24 MW.

Note 3: In-field non-NATA accredited analysis permitted.

9. The works approval holder must ensure that all monitoring equipment used to comply with condition 8 is calibrated in accordance with the manufacturer's specifications.
10. The works approval holder must ensure that all non-continuous sampling and analysis undertaken pursuant to condition 8 is undertaken by a holder of a current accreditation from the NATA for the methods of sampling and analysis relevant to the corresponding relevant parameter.
11. The works approval holder must record the results of all monitoring activity required by condition 8.

Compliance reporting

12. The works approval holder must submit to the CEO an Environmental Commissioning Report within 30 calendar days of the completion date of environmental commissioning for each item of infrastructure specified in Table 2.
13. The works approval holder must ensure the Environmental Commissioning Report required by condition 12 of this works approval includes the following:
 - a) a summary of the environmental commissioning activities undertaken, including timeframes;
 - b) the monitoring results for the exhaust stacks recorded in accordance with condition 8 with comparison against the power station expected output emissions specified in Table 2;
 - c) monitoring results for the WWTPs recorded in accordance with condition 8 with a comparison against the output emission standards for each WWTP specified in condition 1; and the TDS emission limit in condition 7;
 - d) copies of laboratory reports for the monitoring results recorded in accordance with condition 8;
 - e) a review of the works approval holder's performance and compliance against the conditions of this works approval; and
 - f) where they have not been met, measures proposed to meet the manufacturer's design specifications and the conditions of this works approval, together with timeframes for implementing the proposed measures.

Time limited operations phase

Commencement and duration

- 14.** The works approval holder may only commence time limited operations for an item of infrastructure identified in condition 16:
- where the item of infrastructure is not authorised to undertake environmental commissioning, the Environmental Compliance Report as required by condition 2 has been submitted by the works approval holder for that item of infrastructure; and
 - where the item of infrastructure is authorised to undertake environmental commissioning under condition 5, the Environmental Commissioning Report for that item of infrastructure as required by condition 12 has been submitted by the works approval holder.
- 15.** The works approval holder may conduct time limited operations for an item of infrastructure specified in condition 16:
- for a period not exceeding 180 calendar days from the day the works approval holder meets the requirements of condition 14 for that item of infrastructure (with the exception of the Accommodation Resort WWTP and associated infrastructure (Item 5, Table 1) which can operate until 31 July 2024); or
 - until such time as a licence for that item of infrastructure is granted in accordance with Part V of the *Environmental Protection Act 1986*, if one is granted before the end of the period specified in condition 15(a).

Time limited operations requirements

- 16.** During time limited operations, the works approval holder must ensure that the premises infrastructure and equipment listed in Table 6 and located at the corresponding infrastructure location is maintained and operated in accordance with the corresponding operational requirement set out in Table 6.

Table 6: Infrastructure and equipment requirements during time limited operations

	Site infrastructure and equipment	Operational requirement	Infrastructure location
1	CPF	<ul style="list-style-type: none"> Volumes of ore processed through the CPF crushing and screening plant to be recorded Dust controls maintained and operated on infrastructure as specified in condition 1 Dust suppression water applied to operational areas that have the potential to generate dust Water added to the ROM ore to achieve DEM content (approximately 7-8%) for product transport 	At the location shown in Schedule 1, Figure 2 labelled 'Crushing and Processing Plant', 'Primary Crushers', and "Stockyard'
2	Crushing and screening plant at the ROM pad	<ul style="list-style-type: none"> Volumes of ore processed through the crushing and screening plant to be recorded Dust controls maintained and operated 	At the location shown in Schedule 1, Figure 2, labelled 'ROM'

	Site infrastructure and equipment	Operational requirement	Infrastructure location
		on infrastructure as specified in condition 1	
3	Mobile crushing and screening plant	<ul style="list-style-type: none"> Volumes of material processed through the crushing and screening plant to be recorded Dust controls maintained and operated on infrastructure as specified in condition 1 	Mobile across the two locations shown in Schedule 1, Figure 2 labelled 'Mobile Crushing and Screening Plant (indicative Location)'
4	Power station	<ul style="list-style-type: none"> Maintained and serviced as per manufacturer's specifications 	At the location shown in Schedule 1, Figure 2 labelled 'Power station'
5	WWTPs	<ul style="list-style-type: none"> Volumetric flow meters are maintained on each WWTP outlet to the irrigation spray fields All WWTP units maintained and operated in accordance with the requirements as specified in condition 1 	At the locations shown in Schedule 1, Figures 2, 8 and 11 labelled 'Wastewater Treatment Plant'
6	Irrigation spray fields	<ul style="list-style-type: none"> Maintained and operated in accordance with the requirements as specified in condition 1 Irrigation is managed to prevent ponding and pooling of effluent on the ground surface of the irrigation spray field 	At the locations shown in Schedule 1, Figures 2, 8 and 11 labelled 'Irrigation Spray Field'
7	Used tyre storage facility	<ul style="list-style-type: none"> Not more than 11,000 tyres Number of tyres to be recorded Tyre stacks not to exceed 3.7 m in height, 60 m² in area and / or 12.5 tonnes in weight A maximum of four (4) individual stacks grouped, with a clear separation distance of not less than 2.5 m at the base must be maintained between each stack A clear separation distance of not less than 18 m maintained between each stack Be able to retain potentially contaminated water runoff from fire fighting equipment Fire suppression system in accordance with DFES 2020 	At the location shown in Schedule 1, Figure 2 labelled 'Used Tyre Storage'

	Site infrastructure and equipment	Operational requirement	Infrastructure location
8	Landfill	<ul style="list-style-type: none"> • Not more than 9,000 tonnes per annum cumulatively of the following waste types¹: <ul style="list-style-type: none"> ○ Putrescible waste ○ Inert waste type 1 ○ Inert waste type 2 (tyres only) ○ Special waste type 2 (biomedical / clinical waste) ○ Contaminated solid waste (biosolids - sludge cakes from the Accommodation Resort WWTP; and treated soil²) • Volumes and type of waste from each load to be monitored (tonnes) and recorded • Waste disposed within defined trenches • Only four trenches active at any given time (two putrescible trenches; one inert waste trench; and one tyre trench) • Putrescible waste trench to include putrescible waste; special waste type 2; and contaminated solid waste • Separate trenches for inert waste type; and inert waste type 2 (tyres) • Putrescible trenches tipping area no longer than 30 m • Putrescible trenches tipping area no greater than 2 m in height • Special waste type 2 will be covered immediately after its disposal to a depth of at least 1 m with a dense, inert and incombustible material • Putrescible waste to be covered weekly (or as soon as practical after deposit) with sufficient quantities of clean fill or inert waste type 1 • Tyres disposed of in the landfill facility in dedicated trench as follows: <ul style="list-style-type: none"> a) In batches separated from each other by at least 100 mm of soil and each consisting of not more than 1,000 used car tyre equivalent b) Tyres to be covered at regular intervals such that no more than 1,000 used tyre equivalents are left exposed at any one time 	At the location shown in Schedule 1, Figure 2 labelled 'Proposed Landfill/ Bioremediation Facility'

	Site infrastructure and equipment	Operational requirement	Infrastructure location
		c) Once final waste levels in the tyre disposal area are achieved 500 mm of cover is applied	
9	Bulk Fuel Storage Facilities	<ul style="list-style-type: none"> Chemicals and hydrocarbons stored in a manner consistent with AS 1940 Operated in accordance with the <i>Dangerous Goods Safety Act 2004</i> Hydrocarbons stored in impermeable bunds or self bunded tanks/containers Storage tanks shall not be overfilled Concrete aprons flowing into sumps to collect potential spillage and into oily water separator systems 	At the locations shown in Schedule 1, Figures 2 and 11 labelled 'Fuel Storage Facility' and 'Refuelling Area'
10	Concrete batch plant	<ul style="list-style-type: none"> Operated in accordance with manufacturer's specifications Sand and aggregated stored in stockpiles on the ground within the loading operation area (as shown in Schedule 1, Figure 15) Dust suppression to be applied via water carts as required in all works areas All water used in the concrete batching process or washing of trucks collected and recycled back into the plant Wash-down sump and wedge pit periodically cleaned to prevent excessive build up and maintain capacity 	At the location shown in Schedule 1, Figure 2 labelled 'Concrete Batch Plant'

Note 1: As defined in the Landfill Definitions.

Note 2: Soil that meets waste acceptance criteria specified for Class II landfills in accordance with the *Landfill Definitions* after treatment at the bioremediation facility.

17. During time limited operations, the works approval holder must ensure that the emission(s) specified in Table 7, are discharged only from the corresponding discharge point(s) and only at the corresponding discharge point location(s).

Table 7: Authorised discharge points

Emission	Discharge point	Discharge point location
Gas generator exhausts	12 stacks with a minimum height of 8 m above ground level	As shown in Schedule 1, Figure 7
Blended effluent (treated effluent + RO reject)	Irrigation Spray Field – Accommodation Resort	As shown in Schedule 1, Figure 8 'Irrigation Spray Field'
Blended effluent (treated effluent + RO reject)	Irrigation Spray Field – Upper Cane	As shown in Schedule 1, Figure 11 and 12 'Irrigation Spray Field'

Emission	Discharge point	Discharge point location
Treated effluent	CPF Irrigation Spray Filed	As shown in Schedule 1, Figure 2

18. During time limited operations, the works approval holder must ensure that the emissions from the discharge point listed in Table 8 do not exceed the corresponding limit when monitored in accordance with condition 19.

Table 8: Emission and discharge limits during time limited operations

Discharge point	Parameter	Limit
Accommodation Resort Irrigation Spray Field	TDS	3,500 mg/L
Upper Cane Irrigation Spray Field	TDS	3,500 mg/L

Monitoring during time limited operations

19. The works approval holder must monitor emissions during time limited operations in accordance with Table 9.

Table 9: Emissions and discharge monitoring during time limited operations

Discharge point	Monitoring location	Parameter	Frequency	Averaging Period	Unit	Method
Irrigation Spray Fields As shown in Schedule 1, Figures 2, 8 and 11	Flow meter at each WWTP	Volume discharged to irrigation spray field	Continuous	Monthly cumulative	kL/day	Flow meter device
	Flow meter at RO plant	Volume of RO reject to treated effluent tank				
	Final treatment tank sampling tap at: Accommodation Resort WWTP CPF WWTP Upper Cane WWTP	BOD	Monthly	Spot sample	mg/L	AS/NZS 5667.1 AS/NZS 5667.10
		TSS			mg/L	
		Total Nitrogen			mg/L	
		Total Phosphorus			mg/L	
		<i>E.coli</i>			cfu/100 mL	
		pH ¹	Continuous	N/A	pH units	
	Final treatment tank sampling tap at:	Residual free chlorine ¹	Continuous	N/A	mg/L	

Discharge point	Monitoring location	Parameter	Frequency	Averaging Period	Unit	Method
	Accommodation Resort WWTP CPF WWTP					
	Final treatment tank sampling tap at: Accommodation Resort WWTP Upper Cane WWTP	TDS	Monthly	Spot sample	mg/L	

Note 1: In-field non-NATA accredited analysis permitted.

20. All sample analysis, must be undertaken by laboratories with current NATA accreditation for the relevant parameters, unless otherwise specified in Table 9.
21. The works approval holder must record the results of all monitoring activity required by condition 19.

Compliance reporting

22. The works approval holder must submit to the CEO a report on the time limited operations within 30 calendar days of the completion date of time limited operations or 30 calendar days before the expiration date of the works approval, whichever is the sooner.
23. The works approval holder must ensure the report required by condition 22 includes the following:
 - a) a summary of the time limited operations, including timeframes and amount of material and ore processed;
 - b) a summary of the environmental performance of all infrastructure as constructed or installed (as applicable), which includes records detailing the:
 - (i) volumes of wastewater processed; and
 - (ii) volumes of each waste type disposed of to the landfill.
 - c) monitoring results for the WWTPs recorded in accordance with condition 19 with a comparison against the output emission standards for each WWTP specified in condition 1; and the TDS emission limit in condition 18;
 - d) a review of performance and compliance against the conditions of the works approval; and
 - e) where the manufacturer's design specifications and the conditions of this works approval have not been met, what measures will the works approval holder take to meet them, and what timeframes will be required to implement those measures.

Records and reporting (general)

24. The works approval holder must record the following information in relation to complaints received by the works approval holder (whether received directly from a complainant or forwarded to them by the Department or another party) about any

alleged emissions from the premises:

- a) the name and contact details of the complainant, (if provided);
- b) the time and date of the complaint;
- c) the complete details of the complaint and any other concerns or other issues raised; and
- d) the complete details and dates of any action taken by the works approval holder to investigate or respond to any complaint.

25. The works approval holder must maintain accurate and auditable books including the following records, information, reports, and data required by this works approval:

- a) the works conducted in accordance with condition 1;
- b) any maintenance of infrastructure that is performed in the course of complying with conditions of this works approval;
- c) monitoring programmes undertaken in accordance with conditions 8 and 19; and
- d) complaints received under condition 24.

26. The books specified under condition 25 must:

- a) be legible;
- b) if amended, be amended in such a way that the original version(s) and any subsequent amendments remain legible and are capable of retrieval;
- c) be retained by the works approval holder for the duration of the works approval; and
- d) be available to be produced to an inspector or the CEO as required.

Definitions

In this works approval, the terms in Table 10 have the meanings defined.

Table 10: Definitions

Term	Definition
ARI	Average Recurrence Interval.
AS 1940	means Australian Standard AS 1940-2004 <i>The storage and handling of flammable and combustible liquids</i> .
AS/NZS 5667.1	means the Australian Standard AS/NZS 5667.1 <i>Water Quality – Sampling – Guidance on the design of sampling programs, sampling techniques and the preservation and handling of samples</i> .
AS/NZS 5667.10	means the Australian Standard AS/NZS 5667.10 <i>Water Quality – Sampling – Guidance on sampling of waste waters</i> .
BOD	Biochemical Oxygen Demand.
books	has the same meaning given to that term under the EP Act.
CEO	means Chief Executive Officer. CEO for the purposes of notification means: Director General Department administering the <i>Environmental Protection Act 1986</i> Locked Bag 10 Joondalup DC WA 6919 info@dwer.wa.gov.au
cfu/100 mL	means colony forming units per 100 millilitres.
CPF	Central Processing Facility.
Department	means the department established under section 35 of the <i>Public Sector Management Act 1994</i> and designated as responsible for the administration of Part V Division 3 of the EP Act.
DFES 2020	means the document titled “Guidance Note: GN02 Bulk Storage of Rubber Tyres Including Shredded and Crumbed Tyres” published by the Department of Fire and Emergency Services.
discharge	has the same meaning given to that term under the EP Act.
DEM	Dust Extinction Moisture.
emission	has the same meaning given to that term under the EP Act.
environmental commissioning	means the sequence of activities to be undertaken to test equipment integrity and operation, or to determine the environmental performance, of equipment and infrastructure to establish or test a steady state operation and confirm design specifications.
Environmental	means a report on any commissioning activities that have taken place and a demonstration that they have concluded, with focus on emissions

Term	Definition
Commissioning Report	and discharges, waste containment, and other environmental factors.
Environmental Compliance Report	means a report to satisfy the CEO that the conditioned infrastructure and/or equipment has been constructed and/or installed in accordance with the works approval.
Contaminated solid waste	has the meaning defined in Landfill Definitions.
EP Act	<i>Environmental Protection Act 1986 (WA).</i>
EP Regulations	<i>Environmental Protection Regulations 1987 (WA).</i>
Inert Waste Type 1	has the meaning defined in Landfill Definitions.
Inert Waste Type 2	has the meaning defined in Landfill Definitions.
Landfill Definitions	means the document titled “Landfill Waste Classification and Waste Definitions 1996 (as amended 2019)” published by the Chief Executive Officer of the Department of Water and Environmental Regulation as amended from time to time.
MBR	means Membrane Bioreactor.
NATA	National Association of Testing Authorities.
premises	the premises to which this licence applies, as specified at the front of this licence and as shown on the premises map (Figure 1) in Schedule 1 to this works approval.
prescribed premises	has the same meaning given to that term under the EP Act.
Putrescible waste	has the meaning defined in Landfill Definitions.
RO	Reverse Osmosis.
ROM	Run of Mine.
Special Waste Type 2	has the meaning defined in Landfill Definitions.
STP	means standard temperature and pressure (0oCelsius and 101.325 kilopascals respectively), dry.
suitably qualified engineer	means a person who: <ul style="list-style-type: none"> (a) holds a Bachelor of Engineering degree recognised by the Institute of Engineers; and (b) has a minimum of five years of experience working in the field of engineering; or is otherwise approved in writing by the CEO to act in this capacity.
TDS	Total Dissolved Solids.
time limited operations	refers to the operation of the infrastructure and equipment identified under this works approval that is authorised for that purpose, subject to the relevant conditions.

Term	Definition
TSS	Total Suspended Solids.
USEPA Method 2	means the United States Environmental Protection Authority <i>Method 2 – Determination of Stack Gas Velocity Flow Rate</i> .
USEPA Method 6 or 6C	means the United States Environmental Protection Authority <i>Method 6 – Determination of Sulfur Dioxide Emissions from Stationary Sources</i> .
USEPA Method 7E	means the United States Environmental Protection Authority <i>Method 7 – Determination of Nitrogen Oxide Emissions from Stationary Sources</i> .
USEPA Method 10	means the United States Environmental Protection Authority <i>Method 10 – Determination of Carbon Monoxide Emissions from Stationary Sources</i> .
USEPA Method 17	means the United States Environmental Protection Authority <i>Method 17 – Determination of Particulate Matter Emissions from Stationary Sources</i> .
waste	has the same meaning given to that term under the EP Act.
works approval	refers to this document, which evidences the grant of the works approval by the CEO under section 54 of the EP Act, subject to the conditions.
works approval holder	refers to the occupier of the premises being the person to whom this works approval has been granted, as specified at the front of this works approval.
WRL	Waste Rock Landform.
WWTPs	Wastewater Treatment Plants and refers to the Accommodation Resort WWTP, CPF WWTP and Upper Cane WWTP.

END OF CONDITIONS

Schedule 1: Maps

Premises map

The boundary of the prescribed premises is shown in blue outline in the map below (Figure 1)

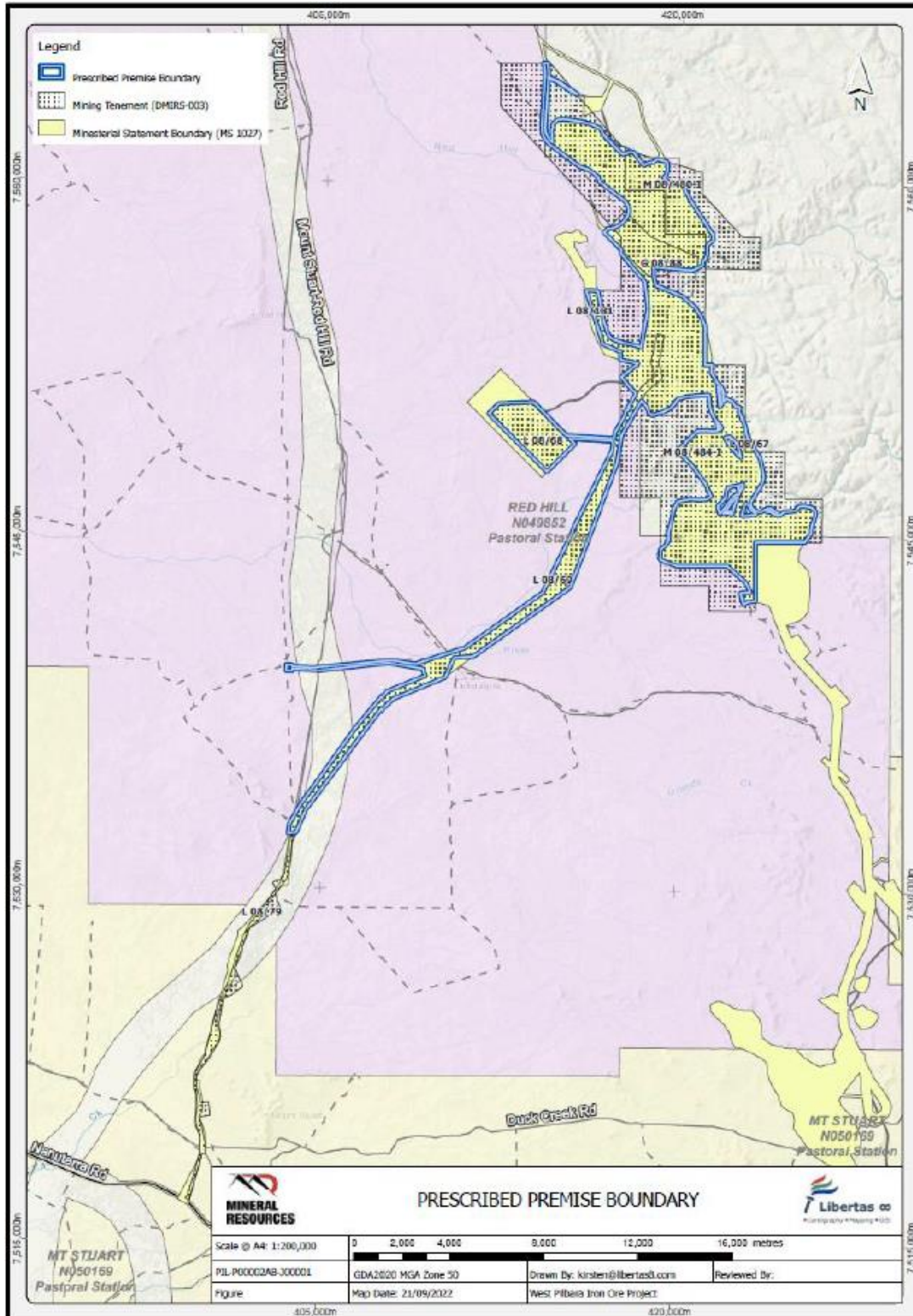

Figure 1: Map of the boundary of the prescribed premises

Infrastructure

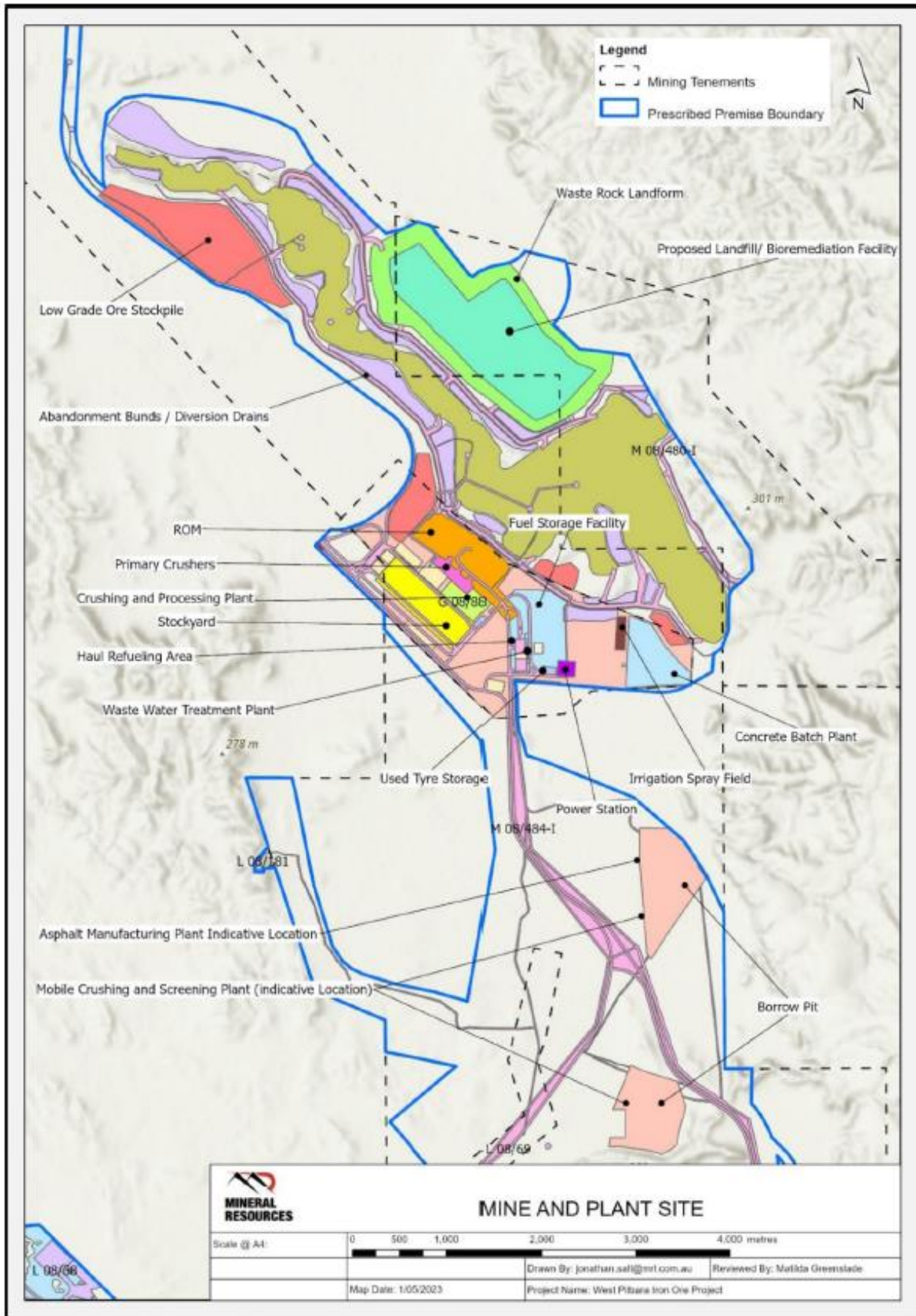

Figure 2: Location of infrastructure

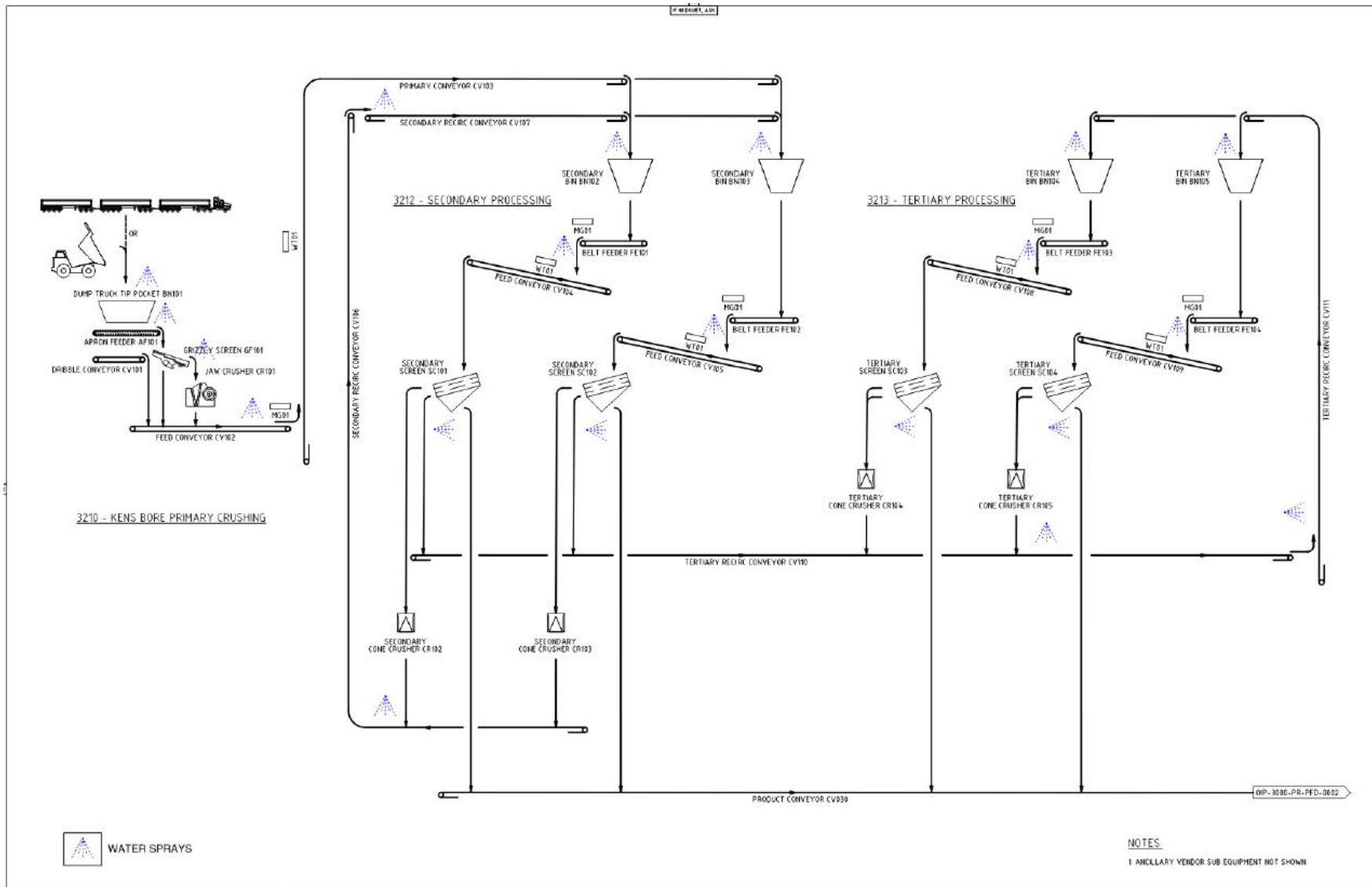

Figure 3: Crushing and Screening Train 1

W6769/2023/1 (amended: 3 September 24)

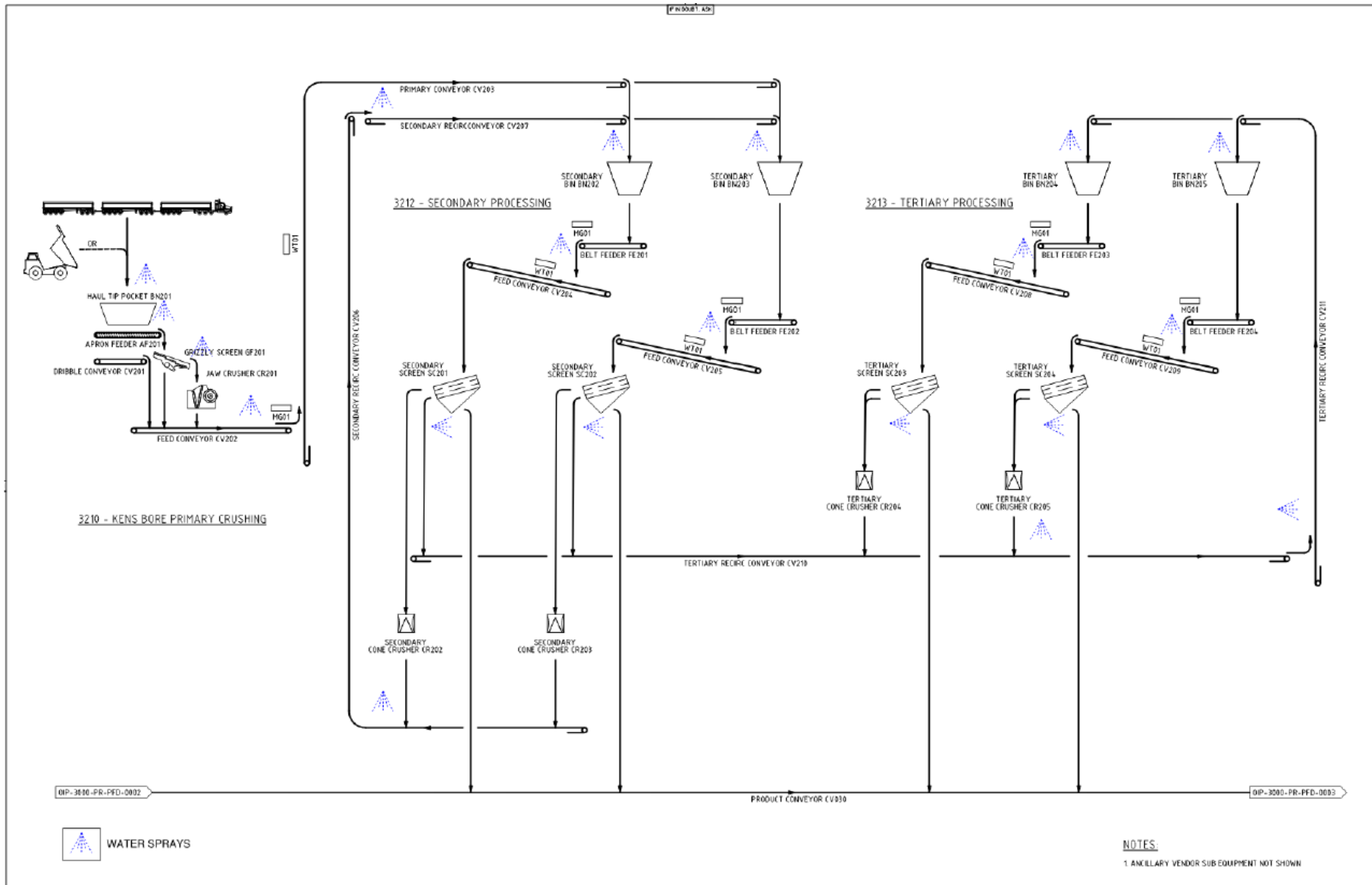

Figure 4: Crushing and Screening Train 2

W6769/2023/1 (amended: 3 September 24)

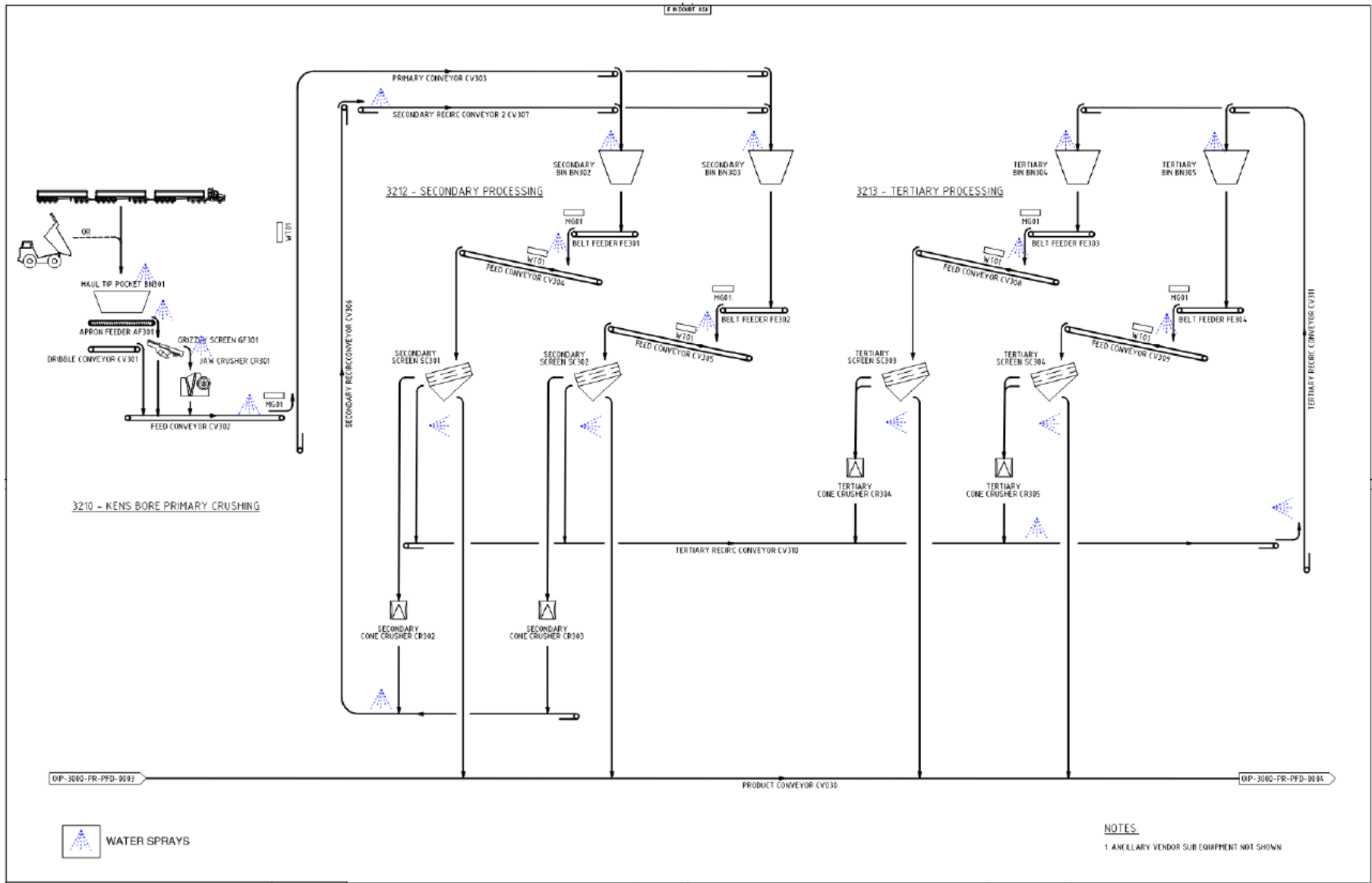

Figure 5: Crushing and Screening Train 3

W6769/2023/1 (amended: 3 September 24)

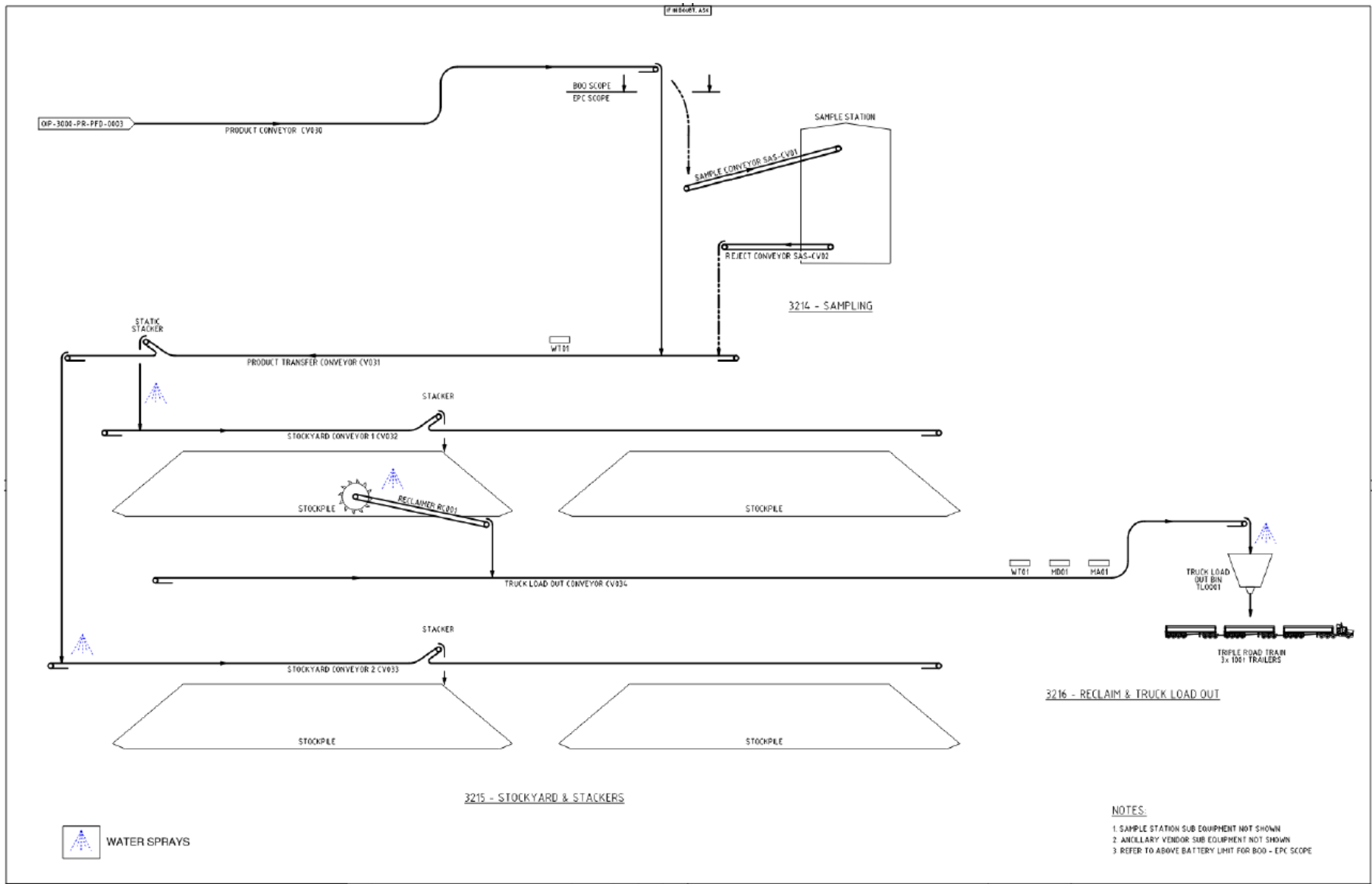

Figure 6: Stockyard

W6769/2023/1 (amended: 3 September 24)

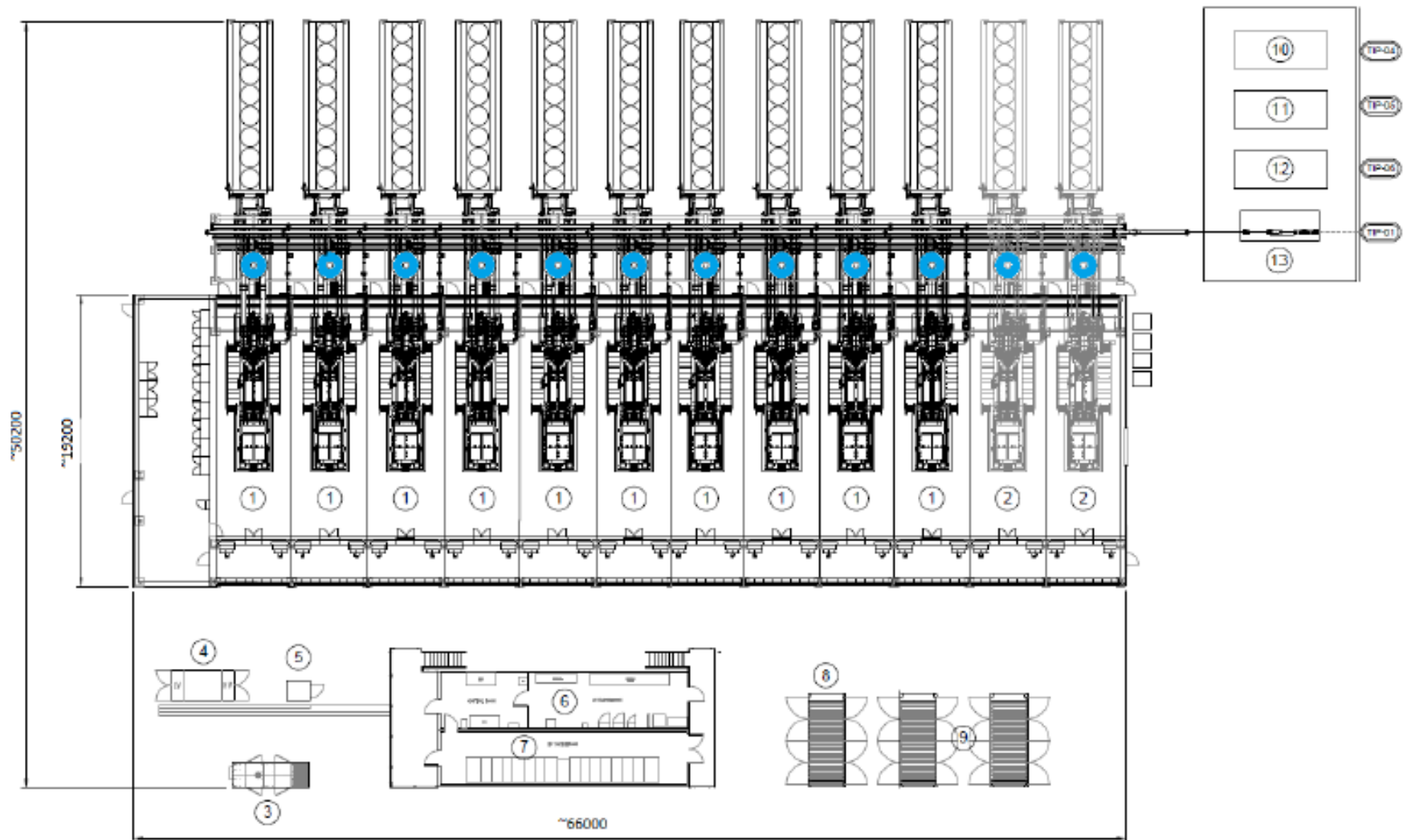

Figure 7: General arrangement of the power station (stack location in blue)

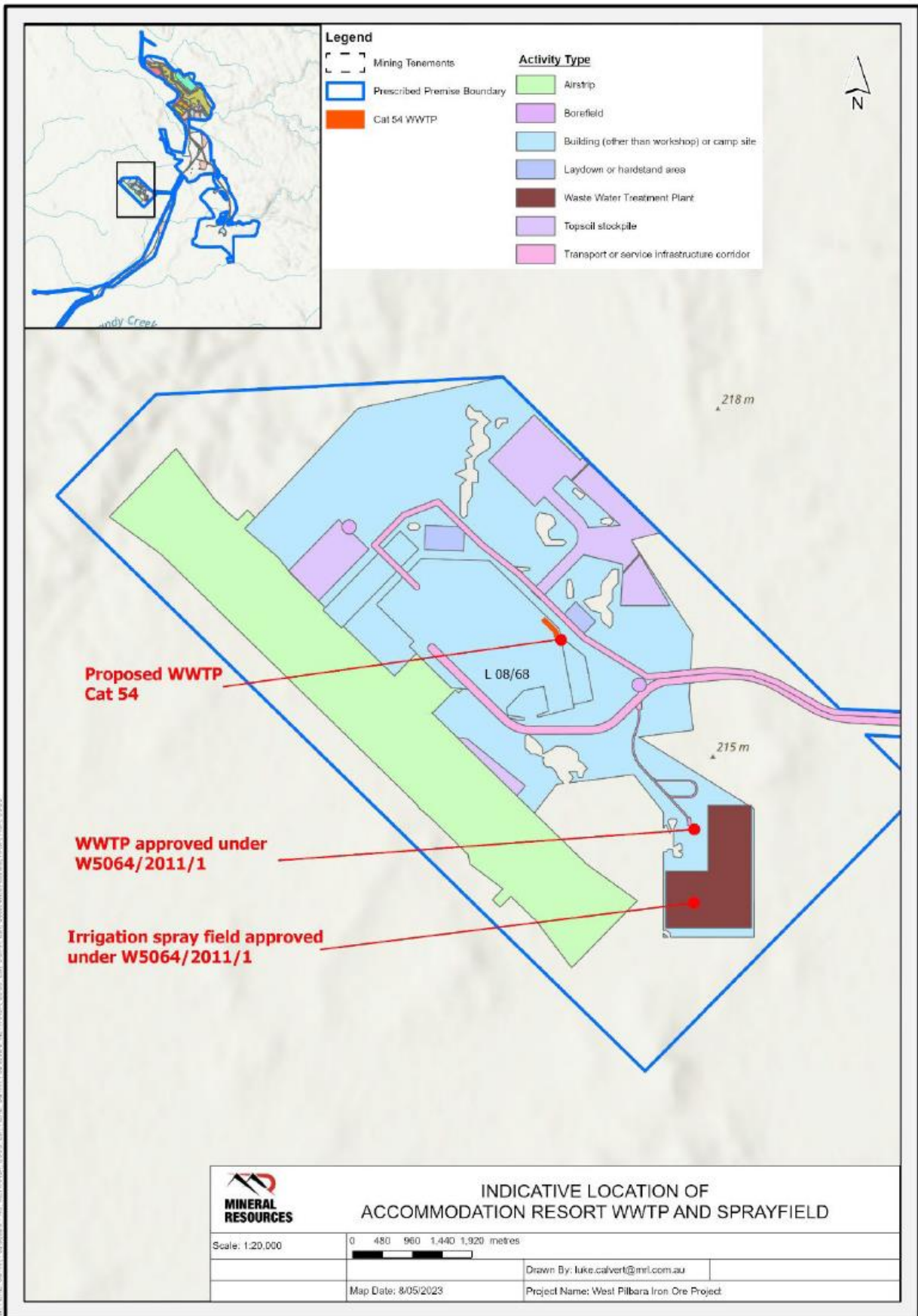

Figure 8: Location of the existing and proposed Accommodation Resort WWTP and Irrigation Spray Field

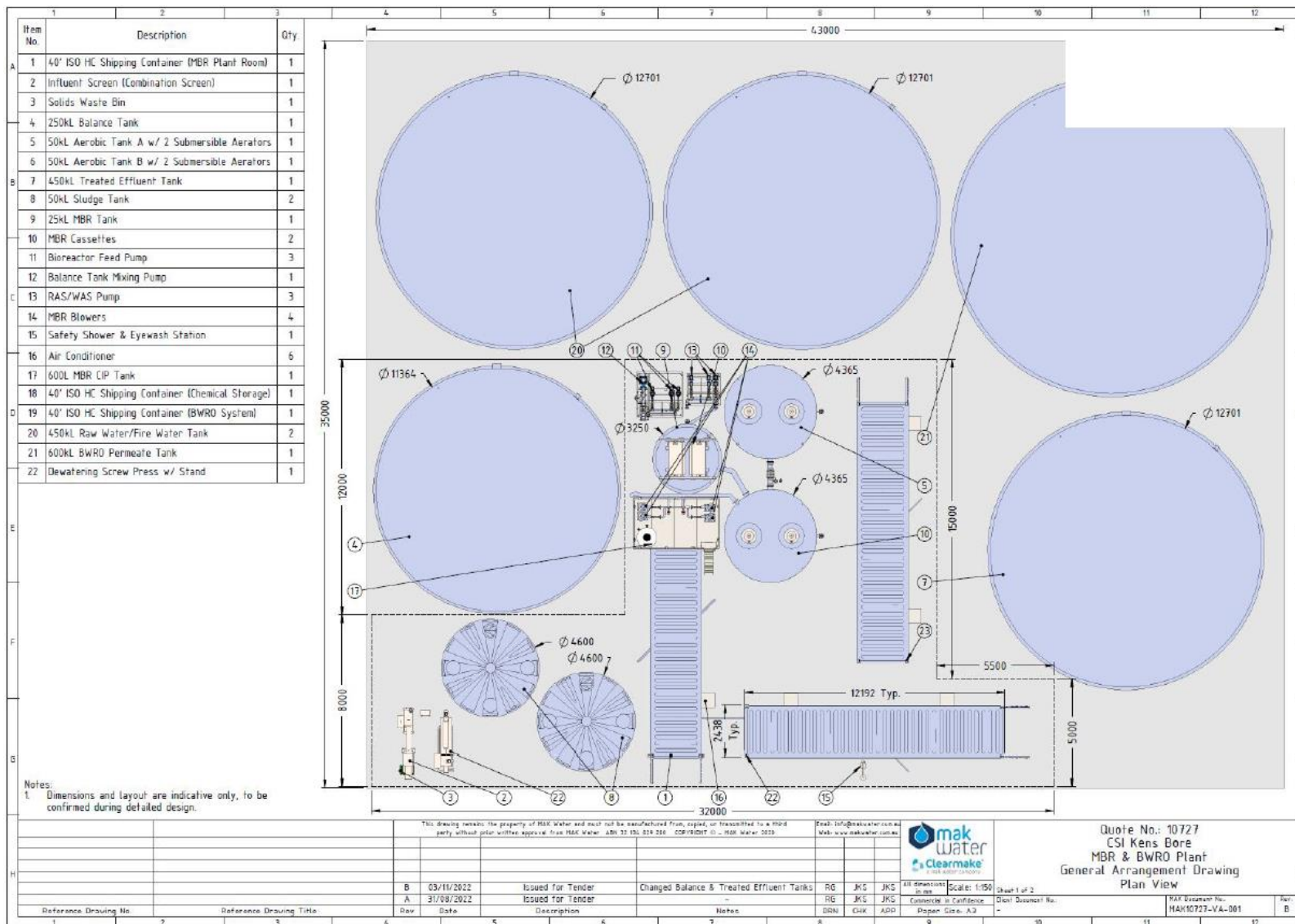

Figure 9: Accommodation Resort WWTP arrangement inclusive of RO infrastructure

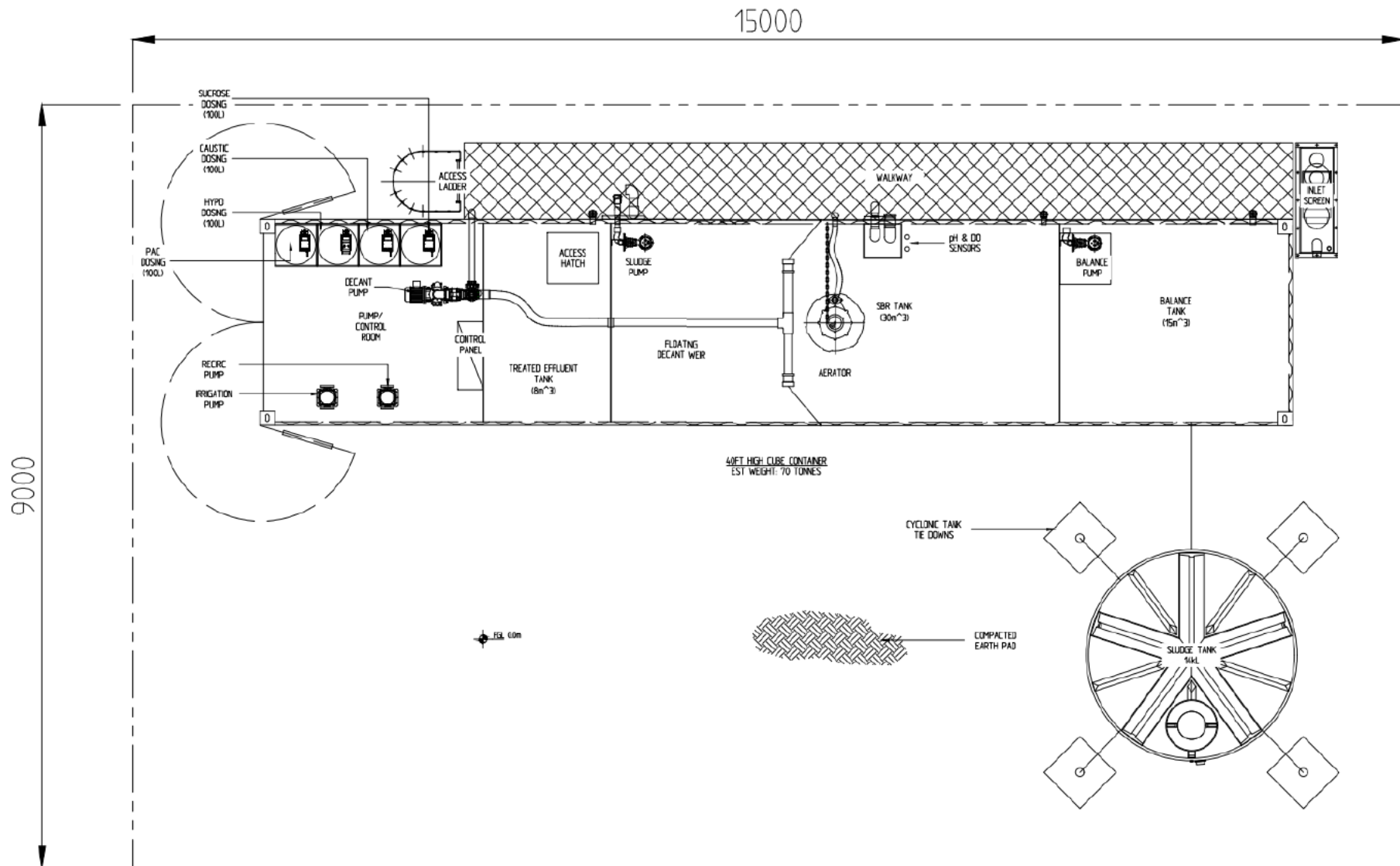

Figure 10: CPF WWTP arrangement

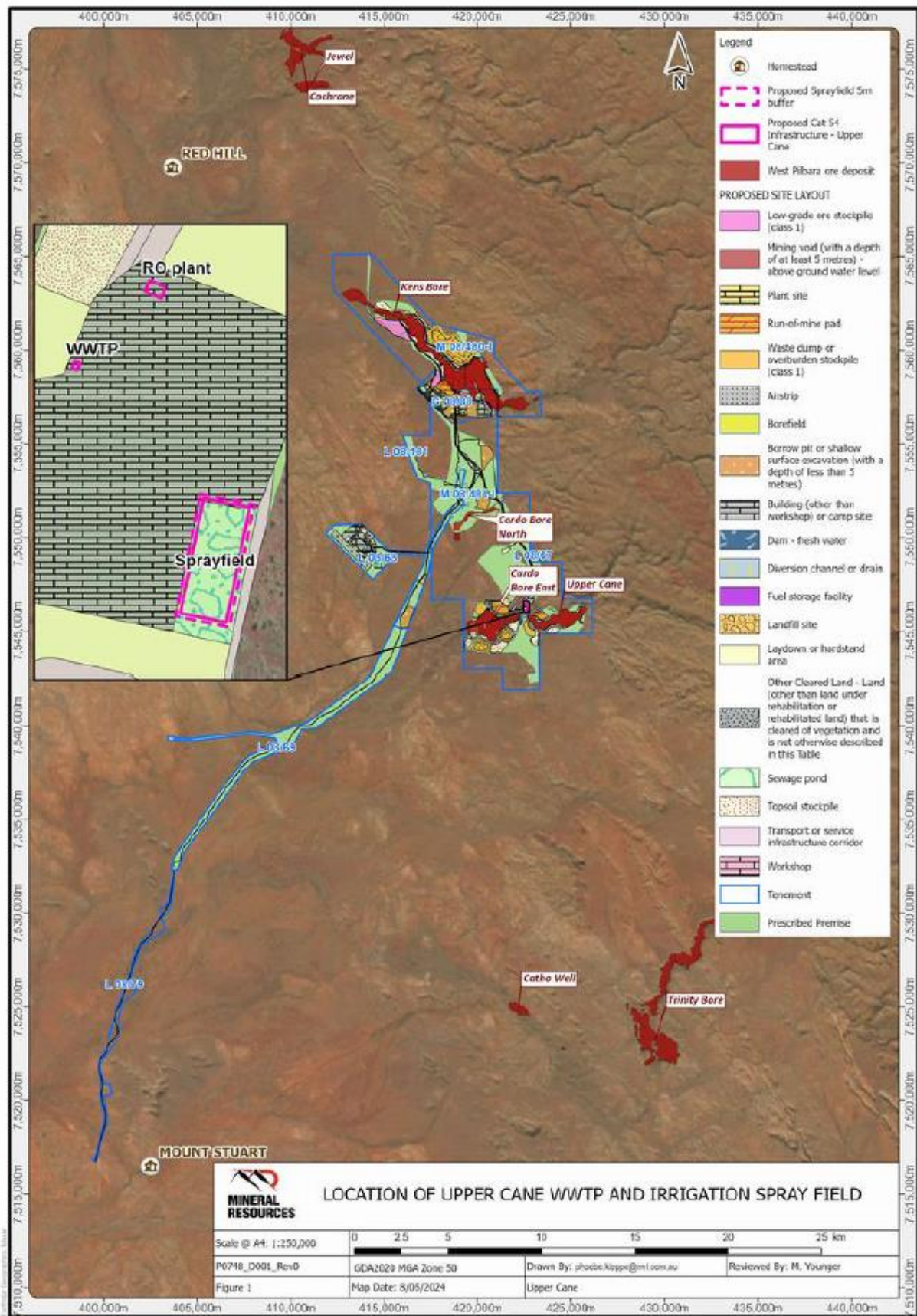

Figure 11: Location of the Upper Cane WWT and Irrigation Spray Field

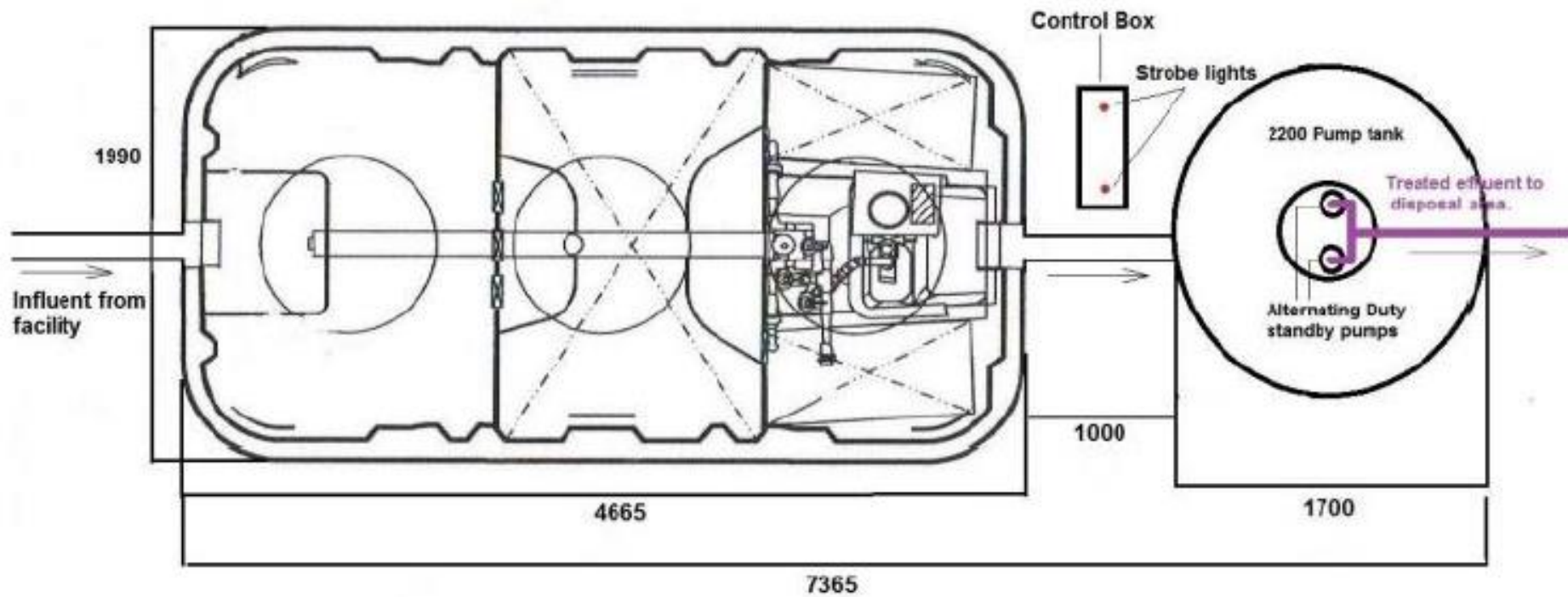

Figure 13: Upper Cane WWTP arrangement

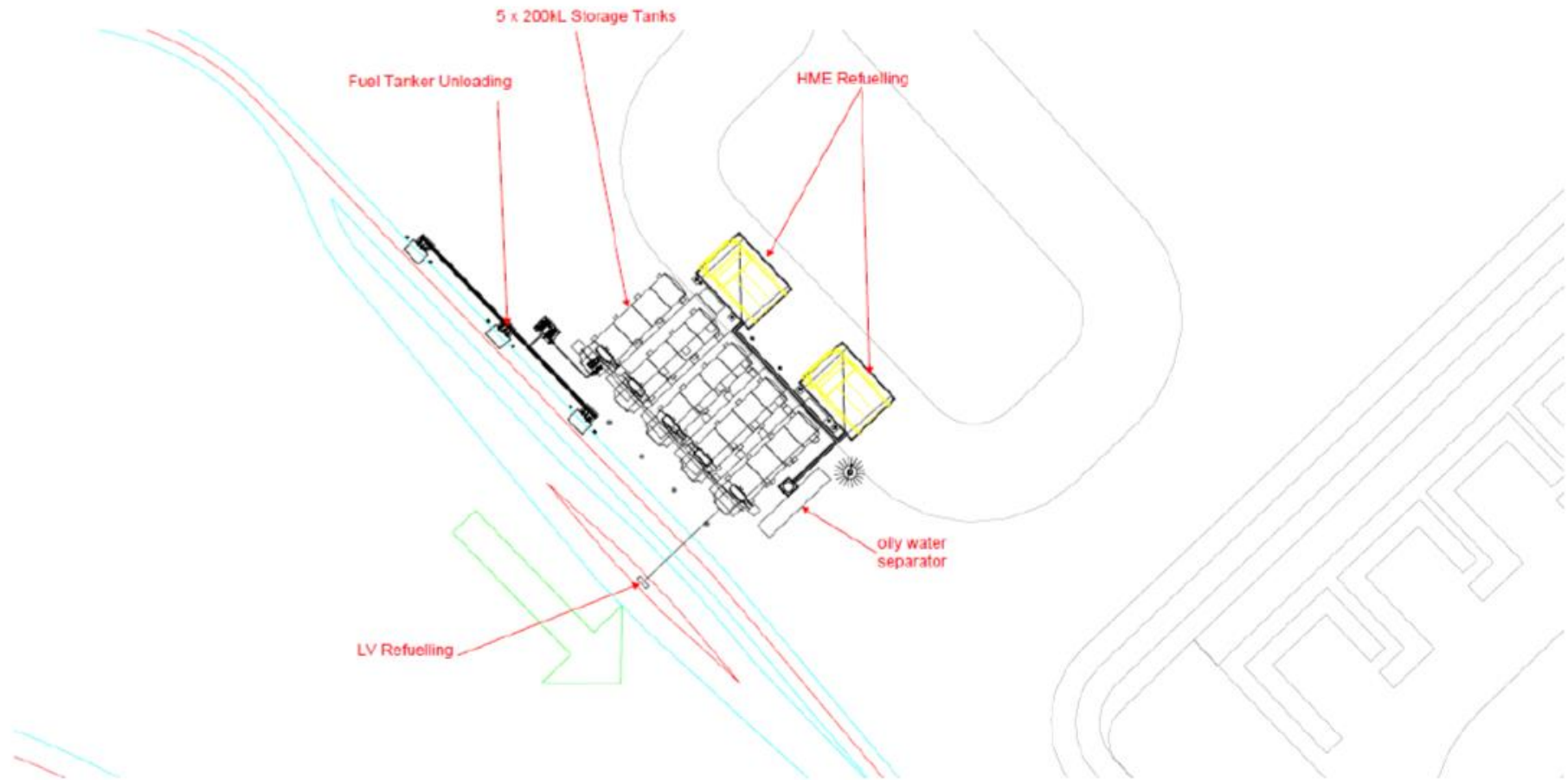

Figure 14: Layout of CPF Bulk Fuel Facility

W6769/2023/1 (amended: 3 September 24)

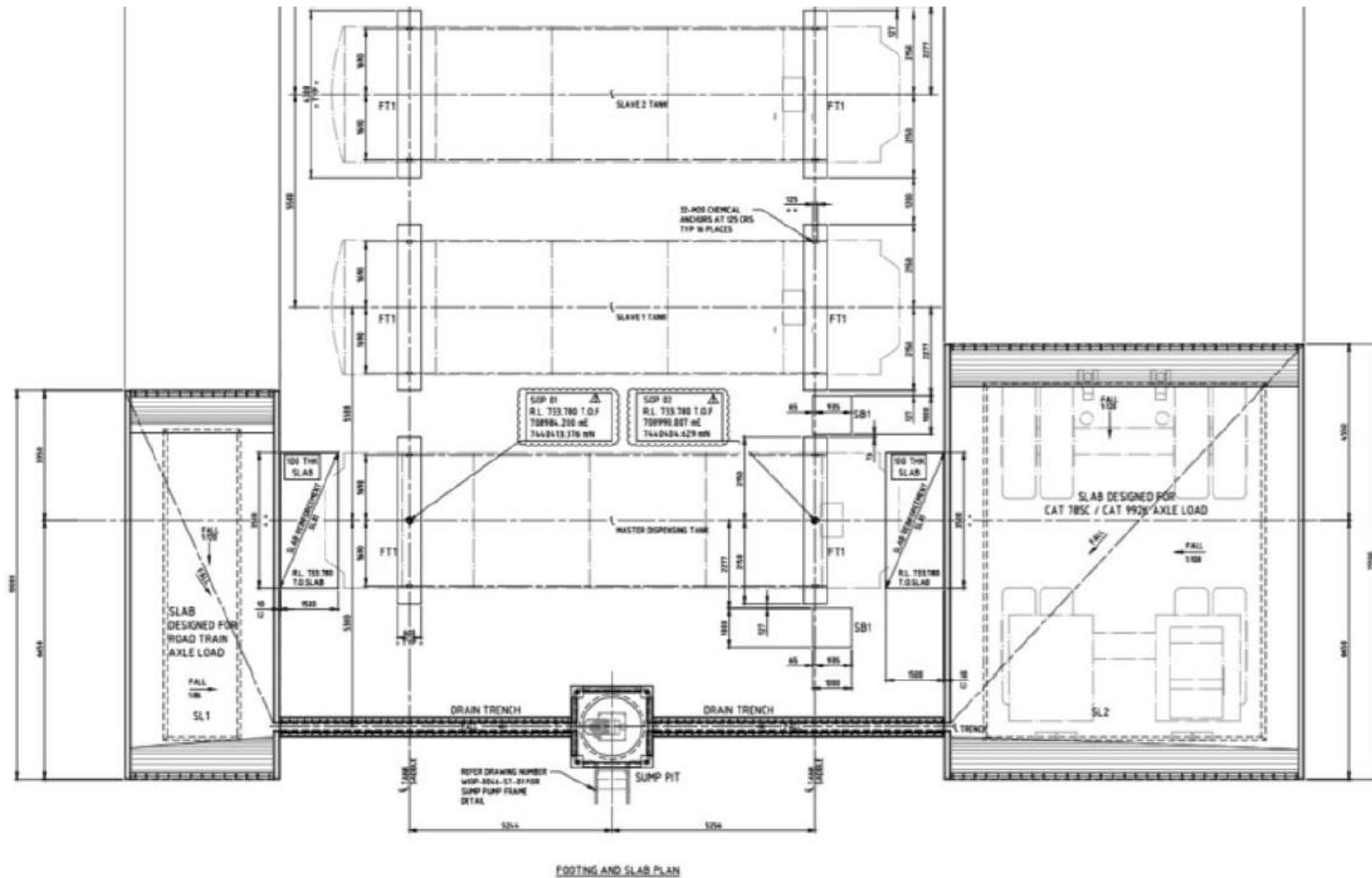

Figure 15: Layout of Upper Cane Bulk Fuel Farm

W6769/2023/1 (amended: 3 September 24)

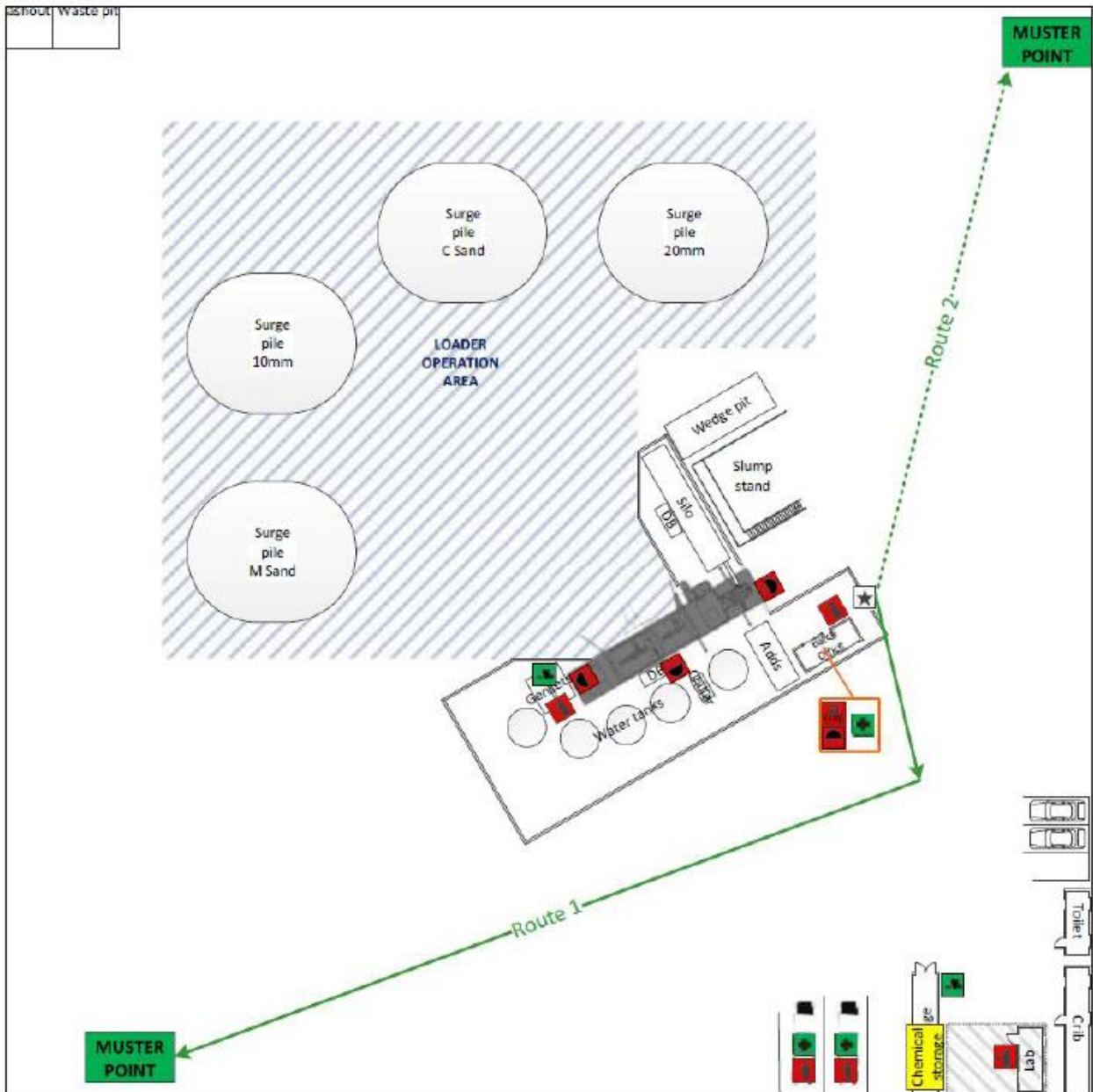

Figure 16: Indicative layout of concrete batch plant