



Works Approval

Works approval number	W6783/2023/1
Works approval holder	Matters Enterprises Pty Ltd trading as RubberGem
ACN	090 053 384
Registered business address	103 Aberdean Street, ALBANY WA 6330
DWER file number	DER2023/000137 / APP-0033345
Duration	12/12/2024 to 11/12/2028
Date of issue	12/12/2024
Date of amendment	20/03/2026
Premises details	RubberGem 6 Lodge Drive, EAST ROCKINGHAM WA 6168 Legal description - Lot 31 on Deposited Plan 425178 Certificate of Title Volume 4041 Folio 917

Prescribed premises category description (Schedule 1, <i>Environmental Protection Regulations 1987</i>)	Assessed design capacity
Category 57: Used tyre storage (general)	200,000 used tyres at any one time
Category 61A: Solid waste facility	45,000 tonnes per annual period
Assessed activities directly related to the above categories	
Clearing of 3.91 hectares of native vegetation in accordance with CPS 9710-1	

This works approval is granted to the works approval holder, subject to the attached conditions, on 20 March 2026, by:

Steve Checker

MANAGER WASTE INDUSTRIES

an officer delegated under section 20 of the *Environmental Protection Act 1986* (WA)

Works approval history

Date	Reference number	Summary of changes
12/12/2024	W6783/2023/1	Works approval granted.
20/03/2026	W6783/2023/1	Amendment to extend the time limited operations phase duration.

Interpretation

In this works approval:

- (a) the words 'including', 'includes' and 'include' in conditions mean "including but not limited to", and similar, as appropriate;
- (b) where any word or phrase is given a defined meaning, any other part of speech or other grammatical form of that word or phrase has a corresponding meaning;
- (c) where tables are used in a condition, each row in a table constitutes a separate condition;
- (d) any reference to an Australian or other standard, guideline, or code of practice in this works approval:
 - (i) if dated, refers to that particular version; and
 - (ii) if not dated, refers to the latest version and therefore may be subject to change over time;
- (e) unless specified otherwise, any reference to a section of an Act refers to that section of the EP Act; and
- (f) unless specified otherwise, all definitions are in accordance with the EP Act.

NOTE: This works approval requires specific conditions to be met but does not provide any implied authorisation for other emissions, discharges, or activities not specified in this works approval.

Works approval conditions

The works approval holder must ensure that the following conditions are complied with:

Construction phase

Infrastructure and equipment

1. The works approval holder must:
 - (a) construct and/or install the infrastructure and/or equipment;
 - (b) in accordance with the corresponding design and construction / installation requirements; and
 - (c) at the corresponding infrastructure location; as set out in Table 1.

Table 1: Design and construction / installation requirements

	Infrastructure	Design and construction / installation requirements	Infrastructure location
1.	External waste tyre and conveyor storage areas	<ol style="list-style-type: none"> (a) To be a concrete lined (permeability of less than 1×10^{-9} m/s) hardstand. (b) Waste tyres to be stored in concrete bunkers designed as specified in Department of Fire and Emergency Services (DFES) 'Guidance Note: GN02 Bulk Storage of Rubber Tyres Including Shredded and Crumbed Tyres' (GN02). (c) Concrete bunkers to be a minimum of 7 m in height. (d) Each bunker to have a maximum floor area of 1,280 m². (e) Radiometric thermal cameras installed for the temperature monitoring of tyres within the bunkers. 	As specified in Schedule 1, Figure 2
2.	Warehouse	<ol style="list-style-type: none"> (a) Flooring to be a concrete lined (permeability of less than 1×10^{-9} m/s) hardstand. (b) To contain the following infrastructure: <ol style="list-style-type: none"> (i). Shredding and granulating plant; (ii). Milling plant; (iii). Colouring, moulding and cutting infrastructure; (iv). Vulcanisation and devulcanisation infrastructure; (v). Capped belt production plant (c) The primary mechanical shredder to be located under the roof canopy of the warehouse. (d) To contain a sprinkler system installed in 	As specified in Schedule 1, Figure 2

	Infrastructure	Design and construction / installation requirements	Infrastructure location
		<p>accordance with AS 2118.1.</p> <p>(e) The shredding and granulating plant to be equipped with dust filtration systems.</p> <p>(f) Activated carbon filtration to be installed for the following processes:</p> <p>(i). Activator 1</p> <p>(ii). Activator 2</p> <p>(iii). Stage 2 Mill 1</p> <p>(iv). Stage 2 Mill 2</p> <p>(v). Banbury</p>	
3.	Product storage areas	(a) To be a concrete lined (permeability of less than 1×10^{-9} m/s) hardstand.	As specified in Schedule 1, Figure 3
4.	Surface water containment infrastructure	<p>(a) To be constructed in accordance with Schedule 1, Figures 4 to 8.</p> <p>(b) Containment collection pits for potentially contaminated stormwater to be constructed of concrete.</p>	As specified in Schedule 1, Figure 2

Air and dust management plan

2. The works approval holder must develop an Air and Dust Management Plan prior to the commencement of time-limited operations commencing as specified in condition 6.
3. The Air and Dust Management Plan specified in condition 2 must include as a minimum:
 - (a) identification of all sources of air and dust emissions;
 - (b) identification of all chemical inputs to the devulcanisation and vulcanisation processes and the potential emissions subsequently generated;
 - (c) mitigation and management measures to reduce and prevent the potential emissions provided in condition 3(a) and 3(b);
 - (d) an air monitoring program in accordance with condition 18;
 - (e) incident and emergency procedures;
 - (f) monitoring, inspection and auditing regimes; and
 - (g) review processes

Compliance reporting

4. The works approval holder must within 90 calendar days of an item of infrastructure or equipment required by condition 1 being constructed and/or installed:
 - (a) undertake an audit of their compliance with the requirements of condition 1; and
 - (b) prepare and submit to the CEO an Environmental Compliance Report on that compliance.

5. The Environmental Compliance Report required by condition 4, must include as a minimum the following:
 - (a) certification by a suitably qualified engineer that the items of infrastructure or component(s) thereof, as specified in condition 1, have been constructed in accordance with the relevant requirements specified in condition 1;
 - (b) as constructed plans and a detailed site plan for each item of infrastructure or component of infrastructure specified in condition 1;
 - (c) the Air and Dust Management Plan as specified in condition 2; and
 - (d) be signed by a person authorised to represent the works approval holder and contains the printed name and position of that person.

Time limited operations phase

Commencement and duration

6. The works approval holder may only commence time limited operations for an item of infrastructure identified in condition 1 where the Environmental Compliance Report as required by condition 5 has been submitted by the works approval holder for that item of infrastructure.
7. The works approval holder may conduct time limited operations for an item of infrastructure specified in condition 8 (as applicable):
 - (a) for a period not exceeding 340 calendar days from the day the works approval holder meets the requirements of condition 6 for that item of infrastructure; or
 - (b) until such time as a licence for that item of infrastructure is granted in accordance with Part V of the *Environmental Protection Act 1986*, if one is granted before the end of the period specified in condition 7(a).
8. During time limited operations, the works approval holder must ensure that the premises infrastructure and equipment listed in Table 2 and located at the corresponding infrastructure location is maintained and operated in accordance with the corresponding operational requirement set out in Table 2.

Table 2: Infrastructure and equipment requirements during time limited operations

	Site infrastructure and equipment	Operational requirement	Infrastructure location
1.	External waste tyre and conveyor storage areas	(a) All waste tyres must be stored externally within concrete bunkers at the locations shown in Schedule 1 Figure 2 in accordance with GN02 as follows: <ol style="list-style-type: none"> (i). Tyre stacks must be no closer than 18 m from all buildings on the same allotment having non-combustible external walls; (ii). Tyre stacks must maintain a separation distance of 18 m from the northern site boundary, and a separation distance of at least 18 m at the western site boundary. (iii). Tyre stacks must be separated from each other by a distance of 	As specified in Schedule 1, Figure 2

	Site infrastructure and equipment	Operational requirement	Infrastructure location
		<p>1.5 m;</p> <p>(iv). Tyre stacks heights must not exceed 3.7 m.</p> <p>(b) The radiometric thermal cameras to monitor the external tyre storage must operate continuously.</p> <p>(c) The radiometric thermal cameras must be connected to an alarm system and activate if the temperature of the tyre stacks reach a temperature of 267 °C.</p> <p>(d) The alarm system is to be connected to the Direct Brigade Alarm system.</p>	
2.	Warehouse	<p>(a) Flooring to be a concrete lined (permeability of less than 1×10^{-9} m/s) hardstand.</p> <p>(b) A sprinkler system installed in accordance with AS 2118.1 must be operational.</p> <p>(c) Dust filtration systems must be operational during the operation of the shredding and granulating plant</p> <p>(d) Must be secure at all times to prevent unauthorised access to the building from persons not employed on the premises.</p> <p>(e) Activated carbon filtration must be maintained and operated to ensure all venting from the following process is directed through the activated carbon filter system:</p> <ul style="list-style-type: none"> (i). Activator 1 (ii). Activator 2 (iii). Stage 2 Mill 1 (iv). Stage 2 Mill 2 (v). Banbury <p>(f) The activated carbon filters must be capable of 95% VOC removal efficiency based on a standard 2 second bed residence time.</p> <p>(g) Filters are to be replaced as informed through on-site carbon filter testing program.</p>	As specified in Schedule 1, Figure 2
3.	Product storage areas	<p>(a) To be a concrete lined (permeability of less than 1×10^{-9} m/s) hardstand.</p> <p>(b) All product must be stored in accordance with GN02.</p>	As specified in Schedule 1, Figure 3

	Site infrastructure and equipment	Operational requirement	Infrastructure location
		<ul style="list-style-type: none"> (c) Tyre granules must be stored within the warehouse as depicted in Schedule 1, Figure 1 Figure 3. (d) Tyre granules must be stored within 1 tonne bulka bags. (e) Finished stock of mats and rolls must be stored within the warehouse as depicted in Schedule 1, Figure 3. (f) Bagged coloured crumb and agricultural mats must be stored within the warehouse as depicted in Schedule 1, Figure 3. (g) Conveyor belt cuts and rubber mat flooring may be stored on the external hardstand as depicted in Schedule 1, Figure 3. 	
4.	Surface water containment infrastructure	<ul style="list-style-type: none"> (a) The bioretention basins must only accept stormwater which has not been comminated with waste, (b) Stormwater which has the potential to be contaminated by waste must be directed to containment collection pits constructed of concrete. (c) The containment collection pits must be maintained to ensure no overtopping occurs. (d) The water within the containment collection pits must only be removed from the premises by a controlled waste carrier to a liquid waste facility licensed for that waste. 	As specified in Schedule 1, Figure 2
5.	Equipment used for processing waste tyres (including shredding, granulating, milling, colouring, moulding, cutting, vulcanisation and devulcanisation)	<ul style="list-style-type: none"> (a) The primary mechanical shredder must be hosed and operated under the roof canopy of the warehouse as depicted in Schedule 1, Figure 2. (b) All other waste tyre processing equipment must be housed and operated inside the warehouse on the premises (as depicted in Schedule 1, Figure 2). (c) Must be operated in a manner that ensures that noise emissions comply with the <i>Environmental Protection (Noise) Regulations 1997</i>. 	As specified in Schedule 1, Figure 2
6.	All on-site fire management and prevention equipment	<ul style="list-style-type: none"> (a) All on-site fire management and prevention equipment to be stored so access is not impeded by infrastructure or equipment used in site operations; and (b) All on-site fire management and 	As specified in Schedule 1, Figure 2

	Site infrastructure and equipment	Operational requirement	Infrastructure location
		prevention equipment must be maintained and in good working order at all times.	

9. The works approval holder must ensure that no visible dust generated from the primary activities crosses the boundary of the premises.

Fire and emergency management

10. The works approval holder must implement a Fire and Emergency Management Plan that is consistent with Australian Standard AS 3745. The plan must include, but is not limited to:
- notification procedures for fire and major spill incidents;
 - how fires will be prevented, detected, responded to, suppressed, contained and controlled for all approved activities addressing all waste types and for all stages of the waste handling, sorting and storage process;
 - in the event of a fire occurring at the premises, how impacts to the environment and human health will be mitigated;
 - how staff will be trained in fire and emergency response on an ongoing, annual basis;
 - details on the firefighting equipment in place and/or accessible at the premises and the fire response capabilities and responsibilities;
 - a premises map displayed at the front of the premises depicting an after hours contact details, plus the location and layout of:
 - fire hose reels, hydrants, sprinklers and isolation points;
 - electrical isolation points;
 - sub-surface drainage infrastructure, including details on flow direction and off-site discharge locations (if applicable);
 - system shutdown points; and
 - fire response access points to the premises; and
 - hazmat manifest displayed at front of the premises.
11. The works approval holder must ensure the fire and emergency management requirements in Table 3 are complied with in the event of a fire.

Table 3: Fire and emergency management requirements

Management Requirement	Fire and emergency management requirements
1. Fire suppression system	The fire suppression system must have a minimum water supply and capacity that provides the maximum hydraulic demand for a minimum of four hours.

Management Requirement		Fire and emergency management requirements
2.	Firewater containment	<p>(a) Firewater that may result at the premises from fire-fighting activities must:</p> <p>(i) be contained on the premises within the capacity of hardstand and low permeability infrastructure; and</p> <p>(ii) not escape to the premises' stormwater system, adjacent premises or exposed soil areas; and</p> <p>(b) The containment capacity for firewater must be calculated with the fire hydrant flow rates prescribed in Australian Standard AS 2419.1:</p> <p>(i) for all fully-enclosed structures; and</p> <p>(ii) individually for each outside hardstand and low permeability catchment area.</p> <p>(c) The containment capacity for firewater must be permanent or achieved automatically when the fire system is activated on the premises.</p> <p>(d) Bunding must be available to prevent firewater from entering the onsite soak well system.</p> <p>(e) Bunding must be available to prevent firewater from entering other drains and discharge points.</p> <p>(f) Arrangements must exist for the removal of firewater, in excess of the containment capacity, by a carrier licensed under the <i>Environmental Protection (Controlled Waste) Regulations 2004</i>, to ensure firewater does not discharge to the environment.</p>
3.	Fire management	<p>(a) The premises must operate an automatic fire detection system within the warehouse designed and installed in accordance with AS1670.1.</p> <p>(b) The size of stockpiles of recycled material (tyre crumb) that could cause a fire hazard must be minimised.</p> <p>(c) A sufficient number of fire hoses on the premises must be provided such that all areas of the premises can be reached.</p> <p>(d) Ensure that any fire on the premises is extinguished as soon as possible.</p>
4.	Notifications ¹	Notifications must follow procedures outlined in the Fire and Emergency Management Plan required by Condition 10.

Note 1: Notification requirements may include advising the Department of Fire and Emergency Services, Western Australian Police, Ambulance Services, the Department of Water and Environmental Regulation and neighbouring premises.

Waste acceptance

- 12.** The works approval holder must only allow waste to be accepted onto the Premises if:
- It is of a type listed in Table 1;
 - The quantity accepted is below any limit listed in Table 1; and
 - It meets any specification listed in Table 1.

Table 1: Waste acceptance

Waste type	Quantity limit	Specification ¹
Inert Waste Type 2 (used tyres only)	Up to 45,000 tonnes per annual period	Up to 200,000 whole used tyres may be stored on the premises at any one time.

Note 1: Additional requirements for the acceptance of controlled waste (including tyres) are set out in the *Environmental Protection (Controlled Waste) Regulations 2004*.

Monitoring during time limited operations

13. The works approval holder must undertake the input monitoring specified in Table 5 during time limited operations.

Table 2: Monitoring of inputs and outputs during time limited operations

Inputs	Parameter	Averaging period	Frequency
Inert Waste Type 2	tonnes	Annual Period	Each load entering the premises

Noise monitoring

14. Within 60 days of the commencement of time-limited operations, the works approval holder must retain the services of a person qualified and experienced in the area of environmental noise assessment and who by their qualifications and experience is eligible to hold membership of the Australian Acoustical Society or the Australian Association of Acoustical Consultants to:
- investigate the nature and extent of noise emissions from the premises;
 - assess in accordance with the methodology required in the *Environmental Protection (Noise) Regulations 1997*, the compliance of the noise emissions from the primary activities, against the relevant assigned levels specified in those Regulations; and
 - compile and submit to the works approval holder within 120 days of the commencement of time-limited operations, a report in accordance with condition 15.
15. A report prepared pursuant to condition 14(c) is to include:
- a description of the methods used for monitoring and/or modelling of noise emissions from the premises;
 - details and the results of the investigation undertaken pursuant to condition 14(a); and
 - details and results of the assessment of the noise emissions from the premises, against the relevant assigned levels in the *Environmental Protection (Noise) Regulations 1997* undertaken pursuant to condition 14(b).
16. The works approval holder must submit to the CEO the report prepared pursuant to condition 14(c) within 14 days of receiving it.
17. Where an assessment pursuant to condition 14(b) indicates that noise emissions do not comply with the relevant assigned levels in the *Environmental Protection (Noise) Regulations 1997*, the works approval holder must:

- (a) within 60 days of receiving an assessment report pursuant to condition 14(c) prepare a plan to ensure the undertaking of the licensed activity will no longer lead to any contravention of the *Environmental Protection (Noise) Regulations 1997*; and
- (b) provide to the CEO a copy of the plan prepared pursuant to condition 17(a) within 30 days of its preparation.

Air monitoring

- 18.** The works approval holder must
- (a) conduct a monitoring programme in accordance with the requirements specified in Schedule 2 and record the results of all monitoring activity conducted under that programme; and
 - (b) provide to the CEO a copy of the monitoring results within 100 days of the commencement of time limited operations in accordance with condition 6.
- 19.** The works approval holder must ensure that all non-continuous sampling and analysis undertaken pursuant to condition 18 is undertaken by a holder of a current accreditation from the National Association of Testing Authorities (NATA) for the methods of sampling and analysis relevant to the corresponding relevant parameter.
- 20.** The works approval holder must develop an Air emissions screening analysis using the monitoring data obtained in accordance with condition 18.
- 21.** The Air emissions screening analysis specified in condition 20 must include as a minimum:
- (a) air emission sources and pollutants from each source;
 - (b) classification of each pollutant;
 - (c) expected air emissions during planned phases (e.g. routine, start-up, maintenance);
 - (d) map with Map Grid Australia (MGA) coordinate references showing the following:
 - (i) premises location, including information of location characteristics;
 - (ii) air emission sources
 - (iii) location of existing and known future sensitive receptors;
 - (iv) topographical contours
 - (e) description of the nature of receptors; and
 - (f) compares the screening concentration values with relevant Ambient air quality guideline values (AGV)

Odour monitoring

- 22.** The works approval holder must retain the services of a suitably qualified person to:
- (a) plan and implement a minimum of three odour field assessments (OFAs) during time-limited operations which follow the plume measurement methodology as specified in the *DWER Guideline: Odour Emissions* and the *European Standard EN 16841-2 (plume method)*. OFAs are to be undertaken:
 - (i) with the prime objective of characterising odour plume extents in the directions of receptors which are most likely to be impacted by odour;
 - (ii) during meteorological and operational conditions most likely to cause impacts at these receptors;

- (iii) over the time limited operations period, with each OFA conducted at least 2 weeks apart; and
 - (b) compile and submit to the works approval holder within six weeks of completion of the final OFA field campaign, an OFA report in accordance with condition 21.
- 23.** An OFA report prepared pursuant to condition 20 is to include:
 - (a) the objective of the assessment;
 - (b) a description of the measurement strategy, measurement conditions and the odour field survey standards that were followed;
 - (c) the following details for each single measurement:
 - (i) odour intensity levels and odour characters;
 - (ii) location (GPS coordinates), date and time;
 - (iii) field survey odour panellist identification; and
 - (iv) details of feedstock volumes held, product volumes held and feedstock accepted to the site during the assessment period.
 - (d) the following representative meteorological measurements as recorded during the measurement cycle:
 - (i) wind speed (metres per second);
 - (ii) wind direction;
 - (iii) cloud cover estimate;
 - (iv) temperature;
 - (e) map(s) depicting the assessment area, odour sources at the premises and other potential odour sources (if relevant);
 - (f) a graphical summary of field survey results showing the recorded odour intensity levels either as a percentage of total observations using pie charts if the stationary plume method was used or as coloured dot points if the dynamic plume method was used that will be superimposed at each point assessed on a map of the survey area;
 - (g) any deviations from the conditions targeted in the OFA strategy and those occurring during the measurement (conclusions should reflect the influence of such deviations on the results); and
 - (h) detailed analysis, interpretation and conclusions with regard to the objectives of the assessment.

Compliance reporting

- 24.** The works approval holder must submit to the CEO a report on the time limited operations within 30 calendar days of the completion date of time limited operations or 90 calendar days before the expiration date of the works approval, whichever is the sooner.
- 25.** The works approval holder must ensure the report required by condition 22 includes the following:
 - (a) a summary of the time limited operations, including timeframes, volume of waste processed and volume of product produced;
 - (b) the Fire and Emergency Management Plan specified by condition 10;

- (c) a summary of input monitoring results obtained during time limited operations under condition 13;
- (d) the air emissions screening analysis specified by condition 21;
- (e) the OFA report specified by condition 23;
- (f) a review of performance and compliance against the conditions of the works approval; and
- (g) where the manufacturer's design specifications and the conditions of this works approval have not been met, what measures will the works approval holder take to meet them, and what timeframes will be required to implement those measures.

Records and reporting (general)

- 26.** The works approval holder must record the following information in relation to complaints received by the works approval holder (whether received directly from a complainant or forwarded to them by the Department or another party) about any alleged emissions from the premises:
- (a) the name and contact details of the complainant, (if provided);
 - (b) the time and date of the complaint;
 - (c) the complete details of the complaint and any other concerns or other issues raised; and
 - (d) the complete details and dates of any action taken by the works approval holder to investigate or respond to any complaint.
- 27.** The works approval holder must maintain accurate and auditable books including the following records, information, reports, and data required by this works approval:
- (a) the works conducted in accordance with condition 1;
 - (b) any maintenance of infrastructure that is performed in the course of complying with condition 8;
 - (c) monitoring programmes undertaken in accordance with conditions 13, 14, 18 and 20; and
 - (d) complaints received under condition 24.
- 28.** The books specified under condition 25 must:
- (a) be legible;
 - (b) if amended, be amended in such a way that the original version(s) and any subsequent amendments remain legible and are capable of retrieval;
 - (c) be retained by the works approval holder for the duration of the works approval; and
 - (d) be available to be produced to an inspector or the CEO as required.

Definitions

In this works approval, the terms in Table 6 have the meanings defined.

Table 6: Definitions

Term	Definition
Australian Standard AS 1851	means Standards Australia AS 1851.2012 <i>Routine service of fire protection systems and equipment</i>
Australian Standard AS 2118.1	means Standards Australia AS 2118.1:2017 <i>Automatic fire sprinkler systems General systems</i>
Australian Standard AS 2419.1	means Standards Australia AS 2419.1 <i>Fire hydrant installations Part 1: System design, installation and commissioning</i>
Australian Standard AS 3745	means Standards Australia AS 3745 <i>Planning for emergencies in facilities</i>
books	has the same meaning given to that term under the EP Act.
CEO	means Chief Executive Officer. CEO for the purposes of notification means: Director General Department administering the <i>Environmental Protection Act 1986</i> Locked Bag 10 Joondalup DC WA 6919 info@dwer.wa.gov.au
Department	means the department established under section 35 of the <i>Public Sector Management Act 1994</i> and designated as responsible for the administration of Part V Division 3 of the EP Act.
discharge	has the same meaning given to that term under the EP Act.
emission	has the same meaning given to that term under the EP Act.
Environmental Compliance Report	means a report to satisfy the CEO that the conditioned infrastructure and/or equipment has been constructed and/or installed in accordance with the works approval.
EP Act	<i>Environmental Protection Act 1986 (WA)</i> .
EP Regulations	<i>Environmental Protection Regulations 1987 (WA)</i> .
Fire and Emergency Management Plan	means a Fire and Emergency Management Plan that meets the requirements specified in condition 6 of this approval
fire management consultant	means a person who: (a) has a minimum of five years of experience working in a

Term	Definition
	<p>supervisory area of fire control system design, installation and commissioning; and</p> <p>(b) is employed by an independent third party external to the works approval holder's business;</p> <p>or is otherwise approved in writing by the CEO to act in this capacity.</p>
firewater	means water that, in the event of a fire, has been used to extinguish a fire, and all materials and combusting products dissolved or suspended within such water, and includes other fire suppressant substances such as foams.
GN02	Means the Department of Fire and Emergency Services <i>Guidance Note:GN02 Bulk Storage of Rubber Tyres Including Shredded and Crumbed Tyres</i> .
premises	the premises to which this works approval applies, as specified at the front of this works approval and as shown on the premises map (Figure 1) in Schedule 1 to this works approval.
prescribed premises	has the same meaning given to that term under the EP Act.
suitably qualified engineer	<p>means a person who:</p> <p>(a) holds a relevant civil or structural engineering tertiary academic qualification; and</p> <p>(b) has a minimum of at least three years of experience working in the area/field of civil engineering.</p>
time limited operations	refers to the operation of the infrastructure and equipment identified under this works approval that is authorised for that purpose, subject to the relevant conditions.
waste	has the same meaning given to that term under the EP Act.
works approval	refers to this document, which evidences the grant of the works approval by the CEO under section 54 of the EP Act, subject to the conditions.
works approval holder	refers to the occupier of the premises being the person to whom this works approval has been granted, as specified at the front of this works approval.

END OF CONDITIONS

Schedule 1: Maps

Premises map

The boundary of the prescribed premises is shown in the map below (Figure 1).

Figure 1: Map of the boundary of the prescribed premises

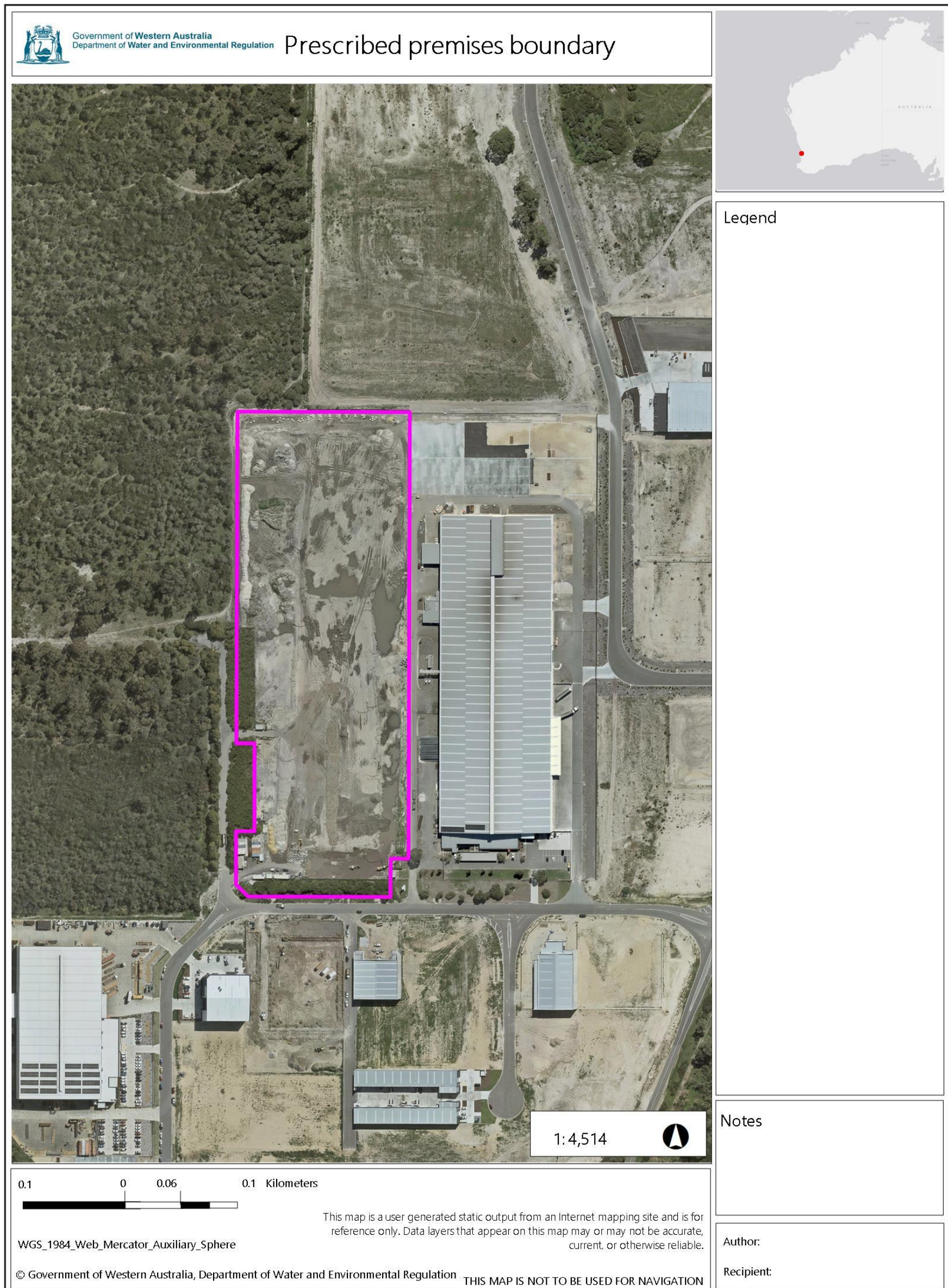

Figure 3: Proposed operations areas

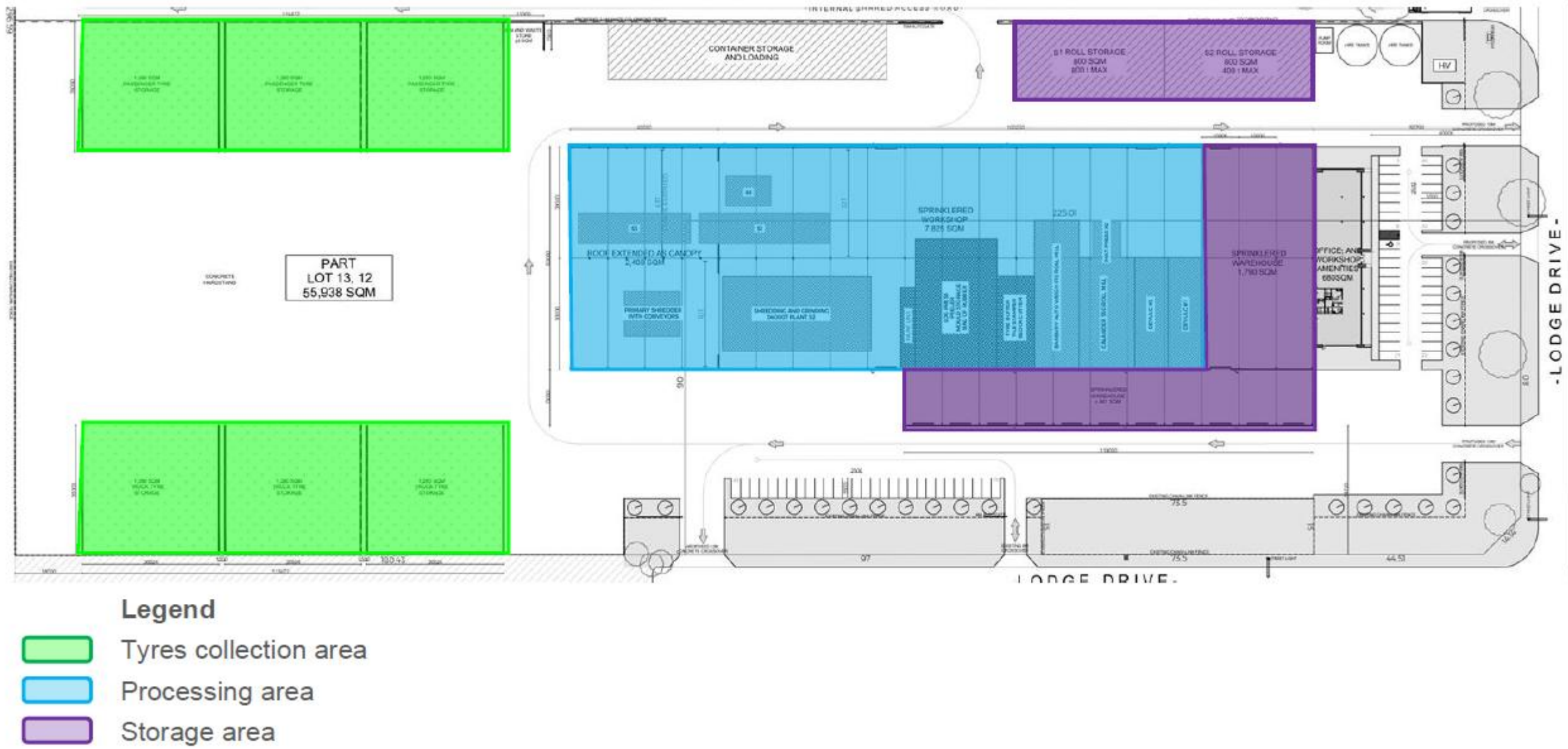

Figure 4: Proposed drainage basin details

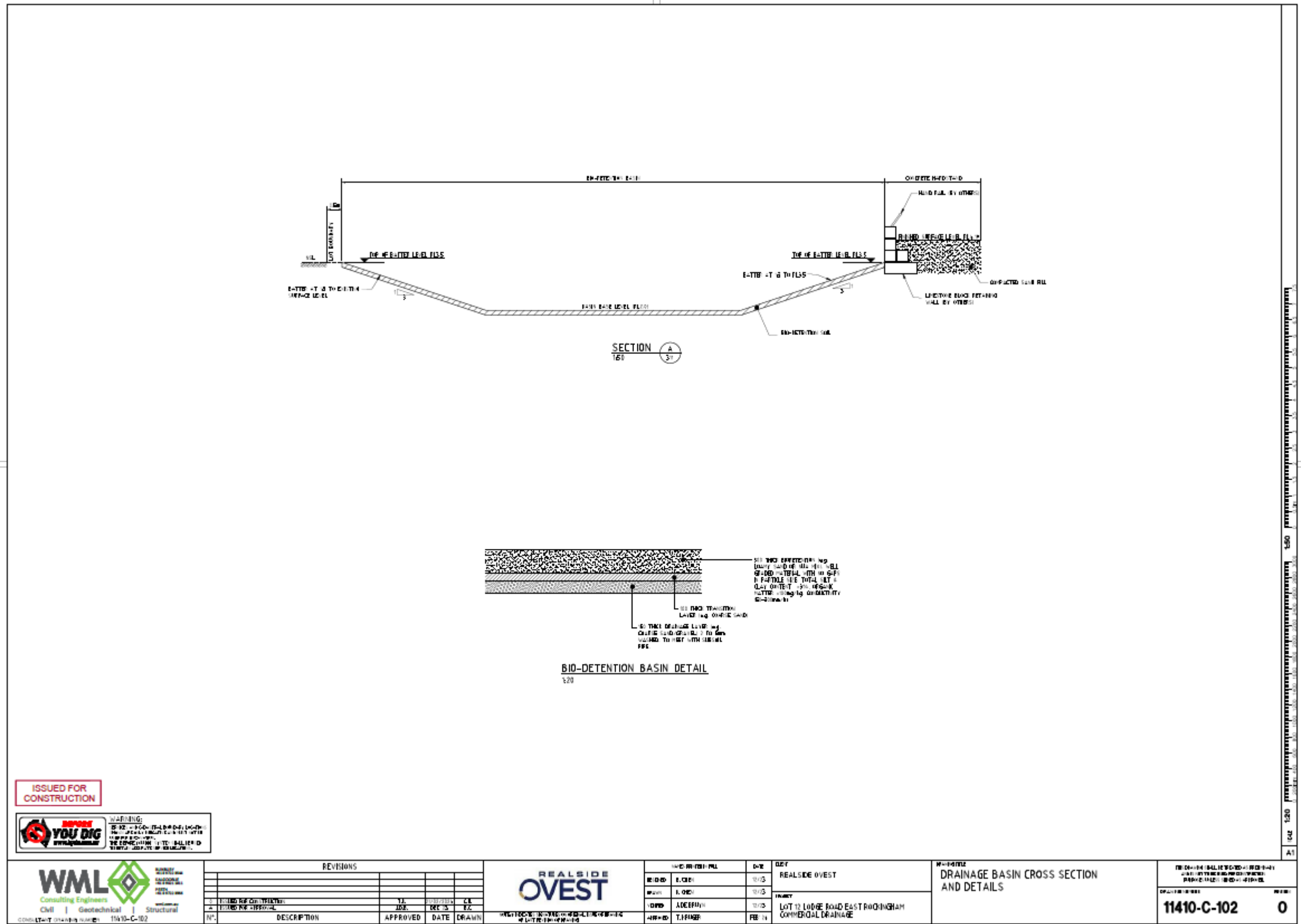

Figure 6: Proposed drainage design

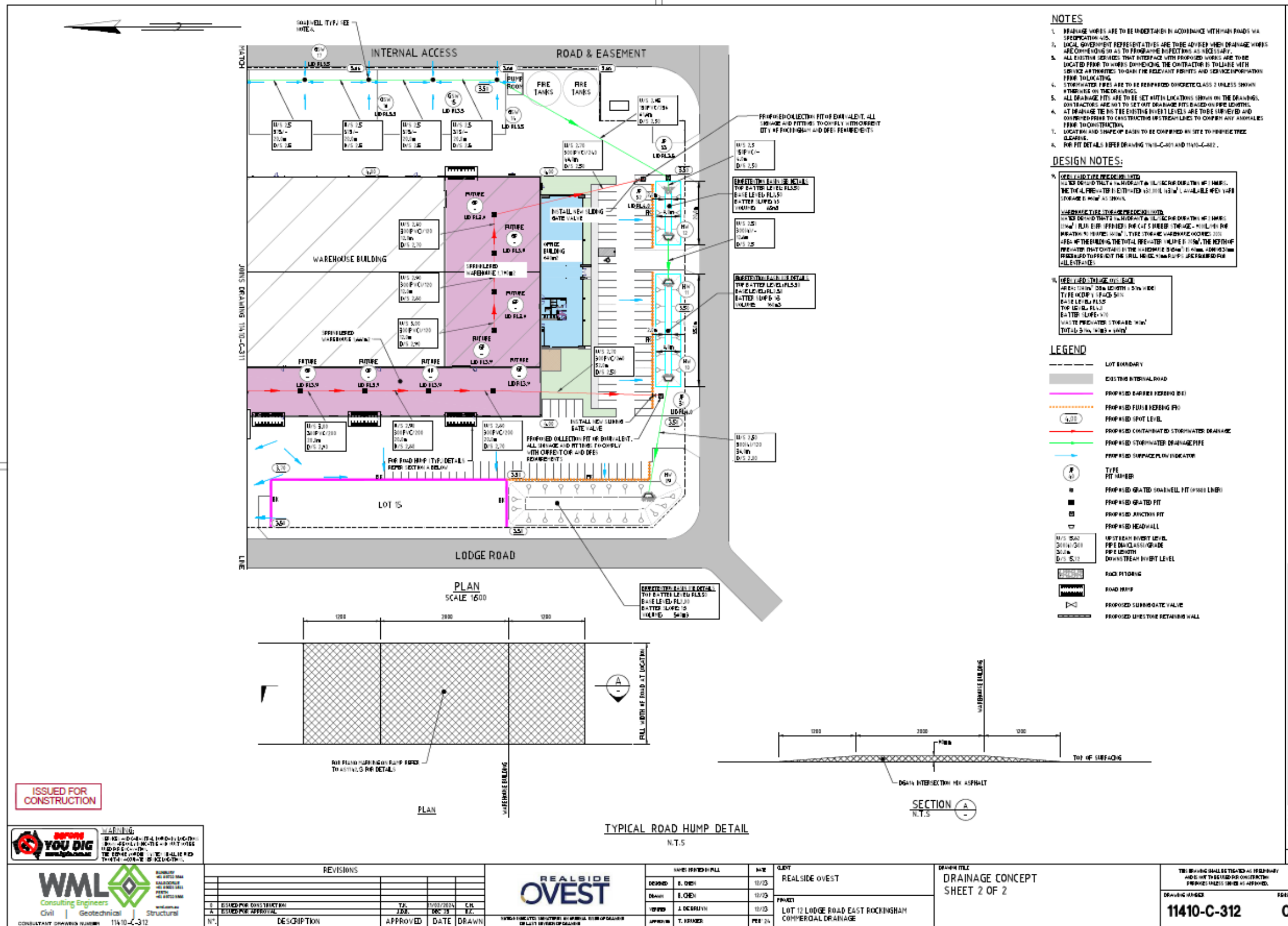
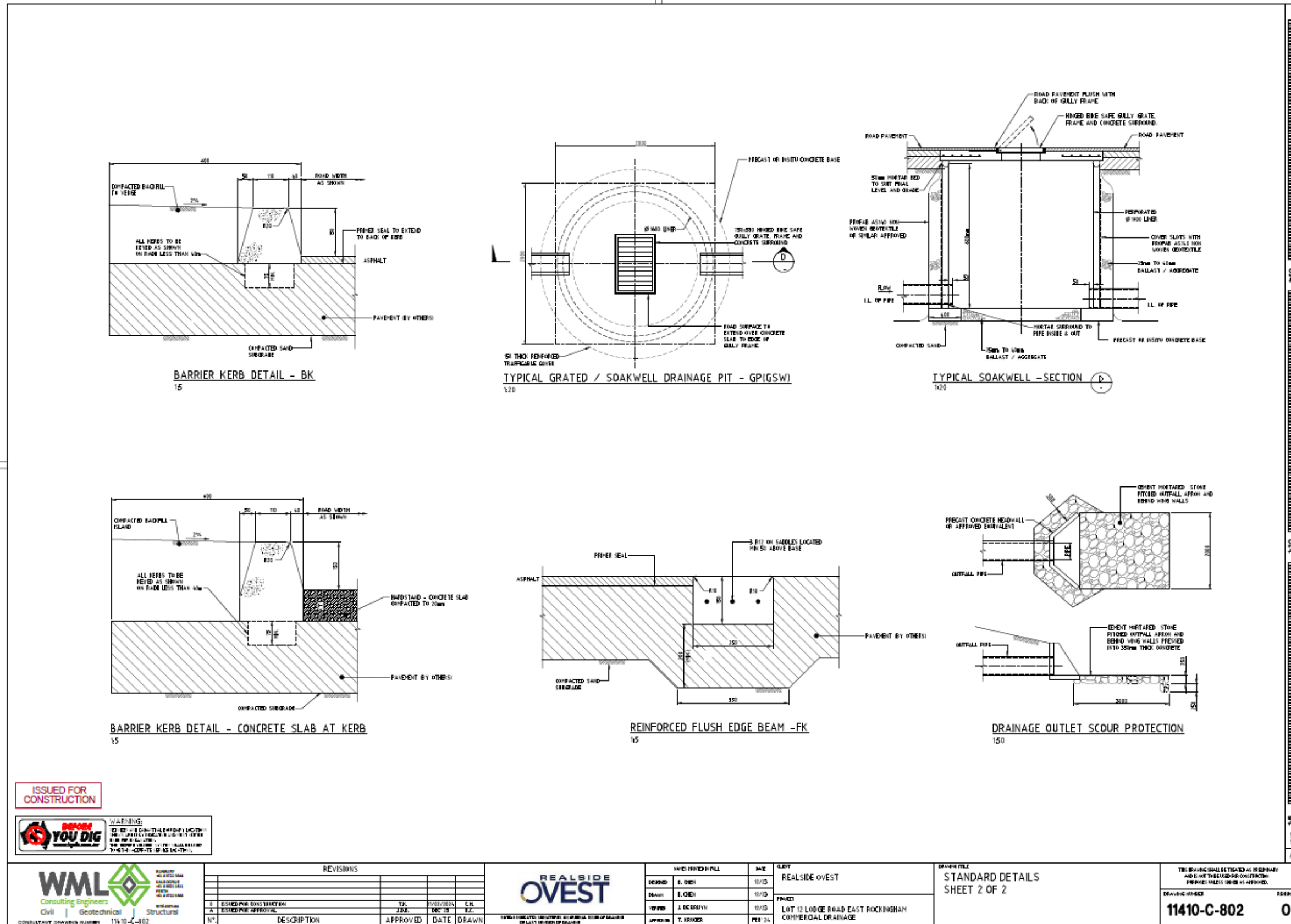

Figure 8: Proposed drainage infrastructure details



1:15
 1:20
 1:25
 1:30
 1:35
 1:40
 1:45
 1:50
 1:55
 2:00
 2:05
 2:10
 2:15
 2:20
 2:25
 2:30
 2:35
 2:40
 2:45
 2:50
 2:55
 3:00
 3:05
 3:10
 3:15
 3:20
 3:25
 3:30
 3:35
 3:40
 3:45
 3:50
 3:55
 4:00
 4:05
 4:10
 4:15
 4:20
 4:25
 4:30
 4:35
 4:40
 4:45
 4:50
 4:55
 5:00
 5:05
 5:10
 5:15
 5:20
 5:25
 5:30
 5:35
 5:40
 5:45
 5:50
 5:55
 6:00
 6:05
 6:10
 6:15
 6:20
 6:25
 6:30
 6:35
 6:40
 6:45
 6:50
 6:55
 7:00
 7:05
 7:10
 7:15
 7:20
 7:25
 7:30
 7:35
 7:40
 7:45
 7:50
 7:55
 8:00
 8:05
 8:10
 8:15
 8:20
 8:25
 8:30
 8:35
 8:40
 8:45
 8:50
 8:55
 9:00
 9:05
 9:10
 9:15
 9:20
 9:25
 9:30
 9:35
 9:40
 9:45
 9:50
 9:55
 10:00
 10:05
 10:10
 10:15
 10:20
 10:25
 10:30
 10:35
 10:40
 10:45
 10:50
 10:55
 11:00
 11:05
 11:10
 11:15
 11:20
 11:25
 11:30
 11:35
 11:40
 11:45
 11:50
 11:55
 12:00
 12:05
 12:10
 12:15
 12:20
 12:25
 12:30
 12:35
 12:40
 12:45
 12:50
 12:55
 13:00
 13:05
 13:10
 13:15
 13:20
 13:25
 13:30
 13:35
 13:40
 13:45
 13:50
 13:55
 14:00
 14:05
 14:10
 14:15
 14:20
 14:25
 14:30
 14:35
 14:40
 14:45
 14:50
 14:55
 15:00
 15:05
 15:10
 15:15
 15:20
 15:25
 15:30
 15:35
 15:40
 15:45
 15:50
 15:55
 16:00
 16:05
 16:10
 16:15
 16:20
 16:25
 16:30
 16:35
 16:40
 16:45
 16:50
 16:55
 17:00
 17:05
 17:10
 17:15
 17:20
 17:25
 17:30
 17:35
 17:40
 17:45
 17:50
 17:55
 18:00
 18:05
 18:10
 18:15
 18:20
 18:25
 18:30
 18:35
 18:40
 18:45
 18:50
 18:55
 19:00
 19:05
 19:10
 19:15
 19:20
 19:25
 19:30
 19:35
 19:40
 19:45
 19:50
 19:55
 20:00
 20:05
 20:10
 20:15
 20:20
 20:25
 20:30
 20:35
 20:40
 20:45
 20:50
 20:55
 21:00
 21:05
 21:10
 21:15
 21:20
 21:25
 21:30
 21:35
 21:40
 21:45
 21:50
 21:55
 22:00
 22:05
 22:10
 22:15
 22:20
 22:25
 22:30
 22:35
 22:40
 22:45
 22:50
 22:55
 23:00
 23:05
 23:10
 23:15
 23:20
 23:25
 23:30
 23:35
 23:40
 23:45
 23:50
 23:55
 24:00
 24:05
 24:10
 24:15
 24:20
 24:25
 24:30
 24:35
 24:40
 24:45
 24:50
 24:55
 25:00
 25:05
 25:10
 25:15
 25:20
 25:25
 25:30
 25:35
 25:40
 25:45
 25:50
 25:55
 26:00
 26:05
 26:10
 26:15
 26:20
 26:25
 26:30
 26:35
 26:40
 26:45
 26:50
 26:55
 27:00
 27:05
 27:10
 27:15
 27:20
 27:25
 27:30
 27:35
 27:40
 27:45
 27:50
 27:55
 28:00
 28:05
 28:10
 28:15
 28:20
 28:25
 28:30
 28:35
 28:40
 28:45
 28:50
 28:55
 29:00
 29:05
 29:10
 29:15
 29:20
 29:25
 29:30
 29:35
 29:40
 29:45
 29:50
 29:55
 30:00
 30:05
 30:10
 30:15
 30:20
 30:25
 30:30
 30:35
 30:40
 30:45
 30:50
 30:55
 31:00
 31:05
 31:10
 31:15
 31:20
 31:25
 31:30
 31:35
 31:40
 31:45
 31:50
 31:55
 32:00
 32:05
 32:10
 32:15
 32:20
 32:25
 32:30
 32:35
 32:40
 32:45
 32:50
 32:55
 33:00
 33:05
 33:10
 33:15
 33:20
 33:25
 33:30
 33:35
 33:40
 33:45
 33:50
 33:55
 34:00
 34:05
 34:10
 34:15
 34:20
 34:25
 34:30
 34:35
 34:40
 34:45
 34:50
 34:55
 35:00
 35:05
 35:10
 35:15
 35:20
 35:25
 35:30
 35:35
 35:40
 35:45
 35:50
 35:55
 36:00
 36:05
 36:10
 36:15
 36:20
 36:25
 36:30
 36:35
 36:40
 36:45
 36:50
 36:55
 37:00
 37:05
 37:10
 37:15
 37:20
 37:25
 37:30
 37:35
 37:40
 37:45
 37:50
 37:55
 38:00
 38:05
 38:10
 38:15
 38:20
 38:25
 38:30
 38:35
 38:40
 38:45
 38:50
 38:55
 39:00
 39:05
 39:10
 39:15
 39:20
 39:25
 39:30
 39:35
 39:40
 39:45
 39:50
 39:55
 40:00
 40:05
 40:10
 40:15
 40:20
 40:25
 40:30
 40:35
 40:40
 40:45
 40:50
 40:55
 41:00
 41:05
 41:10
 41:15
 41:20
 41:25
 41:30
 41:35
 41:40
 41:45
 41:50
 41:55
 42:00
 42:05
 42:10
 42:15
 42:20
 42:25
 42:30
 42:35
 42:40
 42:45
 42:50
 42:55
 43:00
 43:05
 43:10
 43:15
 43:20
 43:25
 43:30
 43:35
 43:40
 43:45
 43:50
 43:55
 44:00
 44:05
 44:10
 44:15
 44:20
 44:25
 44:30
 44:35
 44:40
 44:45
 44:50
 44:55
 45:00
 45:05
 45:10
 45:15
 45:20
 45:25
 45:30
 45:35
 45:40
 45:45
 45:50
 45:55
 46:00
 46:05
 46:10
 46:15
 46:20
 46:25
 46:30
 46:35
 46:40
 46:45
 46:50
 46:55
 47:00
 47:05
 47:10
 47:15
 47:20
 47:25
 47:30
 47:35
 47:40
 47:45
 47:50
 47:55
 48:00
 48:05
 48:10
 48:15
 48:20
 48:25
 48:30
 48:35
 48:40
 48:45
 48:50
 48:55
 49:00
 49:05
 49:10
 49:15
 49:20
 49:25
 49:30
 49:35
 49:40
 49:45
 49:50
 49:55
 50:00
 50:05
 50:10
 50:15
 50:20
 50:25
 50:30
 50:35
 50:40
 50:45
 50:50
 50:55
 51:00
 51:05
 51:10
 51:15
 51:20
 51:25
 51:30
 51:35
 51:40
 51:45
 51:50
 51:55
 52:00
 52:05
 52:10
 52:15
 52:20
 52:25
 52:30
 52:35
 52:40
 52:45
 52:50
 52:55
 53:00
 53:05
 53:10
 53:15
 53:20
 53:25
 53:30
 53:35
 53:40
 53:45
 53:50
 53:55
 54:00
 54:05
 54:10
 54:15
 54:20
 54:25
 54:30
 54:35
 54:40
 54:45
 54:50
 54:55
 55:00
 55:05
 55:10
 55:15
 55:20
 55:25
 55:30
 55:35
 55:40
 55:45
 55:50
 55:55
 56:00
 56:05
 56:10
 56:15
 56:20
 56:25
 56:30
 56:35
 56:40
 56:45
 56:50
 56:55
 57:00
 57:05
 57:10
 57:15
 57:20
 57:25
 57:30
 57:35
 57:40
 57:45
 57:50
 57:55
 58:00
 58:05
 58:10
 58:15
 58:20
 58:25
 58:30
 58:35
 58:40
 58:45
 58:50
 58:55
 59:00
 59:05
 59:10
 59:15
 59:20
 59:25
 59:30
 59:35
 59:40
 59:45
 59:50
 59:55
 60:00
 60:05
 60:10
 60:15
 60:20
 60:25
 60:30
 60:35
 60:40
 60:45
 60:50
 60:55
 61:00
 61:05
 61:10
 61:15
 61:20
 61:25
 61:30
 61:35
 61:40
 61:45
 61:50
 61:55
 62:00
 62:05
 62:10
 62:15
 62:20
 62:25
 62:30
 62:35
 62:40
 62:45
 62:50
 62:55
 63:00
 63:05
 63:10
 63:15
 63:20
 63:25
 63:30
 63:35
 63:40
 63:45
 63:50
 63:55
 64:00
 64:05
 64:10
 64:15
 64:20
 64:25
 64:30
 64:35
 64:40
 64:45
 64:50
 64:55
 65:00
 65:05
 65:10
 65:15
 65:20
 65:25
 65:30
 65:35
 65:40
 65:45
 65:50
 65:55
 66:00
 66:05
 66:10
 66:15
 66:20
 66:25
 66:30
 66:35
 66:40
 66:45
 66:50
 66:55
 67:00
 67:05
 67:10
 67:15
 67:20
 67:25
 67:30
 67:35
 67:40
 67:45
 67:50
 67:55
 68:00
 68:05
 68:10
 68:15
 68:20
 68:25
 68:30
 68:35
 68:40
 68:45
 68:50
 68:55
 69:00
 69:05
 69:10
 69:15
 69:20
 69:25
 69:30
 69:35
 69:40
 69:45
 69:50
 69:55
 70:00
 70:05
 70:10
 70:15
 70:20
 70:25
 70:30
 70:35
 70:40
 70:45
 70:50
 70:55
 71:00
 71:05
 71:10
 71:15
 71:20
 71:25
 71:30
 71:35
 71:40
 71:45
 71:50
 71:55
 72:00
 72:05
 72:10
 72:15
 72:20
 72:25
 72:30
 72:35
 72:40
 72:45
 72:50
 72:55
 73:00
 73:05
 73:10
 73:15
 73:20
 73:25
 73:30
 73:35
 73:40
 73:45
 73:50
 73:55
 74:00
 74:05
 74:10
 74:15
 74:20
 74:25
 74:30
 74:35
 74:40
 74:45
 74:50
 74:55
 75:00
 75:05
 75:10
 75:15
 75:20
 75:25
 75:30
 75:35
 75:40
 75:45
 75:50
 75:55
 76:00
 76:05
 76:10
 76:15
 76:20
 76:25
 76:30
 76:35
 76:40
 76:45
 76:50
 76:55
 77:00
 77:05
 77:10
 77:15
 77:20
 77:25
 77:30
 77:35
 77:40
 77:45
 77:50
 77:55
 78:00
 78:05
 78:10
 78:15
 78:20
 78:25
 78:30
 78:35
 78:40
 78:45
 78:50
 78:55
 79:00
 79:05
 79:10
 79:15
 79:20
 79:25
 79:30
 79:35
 79:40
 79:45
 79:50
 79:55
 80:00
 80:05
 80:10
 80:15
 80:20
 80:25
 80:30
 80:35
 80:40
 80:45
 80:50
 80:55
 81:00
 81:05
 81:10
 81:15
 81:20
 81:25
 81:30
 81:35
 81:40
 81:45
 81:50
 81:55
 82:00
 82:05
 82:10
 82:15
 82:20
 82:25
 82:30
 82:35
 82:40
 82:45
 82:50
 82:55
 83:00
 83:05
 83:10
 83:15
 83:20
 83:25
 83:30
 83:35
 83:40
 83:45
 83:50
 83:55
 84:00
 84:05
 84:10
 84:15
 84:20
 84:25
 84:30
 84:35
 84:40
 84:45
 84:50
 84:55
 85:00
 85:05
 85:10
 85:15
 85:20
 85:25
 85:30
 85:35
 85:40
 85:45
 85:50
 85:55
 86:00
 86:05
 86:10
 86:15
 86:20
 86:25
 86:30
 86:35
 86:40
 86:45
 86:50
 86:55
 87:00
 87:05
 87:10
 87:15
 87:20
 87:25
 87:30
 87:35
 87:40
 87:45
 87:50
 87:55
 88:00
 88:05
 88:10
 88:15
 88:20
 88:25
 88:30
 88:35
 88:40
 88:45
 88:50
 88:55
 89:00
 89:05
 89:10
 89:15
 89:20
 89:25
 89:30
 89:35
 89:40
 89:45
 89:50
 89:55
 90:00
 90:05
 90:10
 90:15
 90:20
 90:25
 90:30
 90:35
 90:40
 90:45
 90:50
 90:55
 91:00
 91:05
 91:10
 91:15
 91:20
 91:25
 91:30
 91:35
 91:40
 91:45
 91:50
 91:55
 92:00
 92:05
 92:10
 92:15
 92:20
 92:25
 92:30
 92:35
 92:40
 92:45
 92:50
 92:55
 93:00
 93:05
 93:10
 93:15
 93:20
 93:25
 93:30
 93:35
 93:40
 93:45
 93:50
 93:55
 94:00
 94:05
 94:10
 94:15
 94:20
 94:25
 94:30
 94:35
 94:40
 94:45
 94:50
 94:55
 95:00
 95:05
 95:10
 95:15
 95:20
 95:25
 95:30
 95:35
 95:40
 95:45
 95:50
 95:55
 96:00
 96:05
 96:10
 96:15
 96:20
 96:25
 96:30
 96:35
 96:40
 96:45
 96:50
 96:55
 97:00
 97:05
 97:10
 97:15
 97:20
 97:25
 97:30
 97:35
 97:40
 97:45
 97:50
 97:55
 98:00

Schedule 2: Monitoring

Emission monitoring

The works approval holder must monitor emissions in accordance with the requirements specified in Table 7 and record the results of all such monitoring.

Note: The monitoring locations specified in Table 7 refer to the air emission points associated with:

- A1: Dust extraction system
- A2: Activator 1;
- A3: Activator 2;
- A4: Stage 2 Mill 1;
- A5: Stage 2 Mill 2; and
- A6: Banbury

Table 7: Emissions and discharge monitoring

Monitoring location	Parameter	Frequency	Averaging period	Unit	Sampling method	Analysis method ¹
A1-A6	Flow rate	Twice during time-limited operations, with at least 30 days between sampling events.	As specified by USEPA Method 2	m ³ /s	USEPA Method 2	USEPA Method 2
A1-A6	Temperature			°C		
A1	Velocity			m/s		
A1-A6	Moisture	Sampling to be performed when devulcanization process is stable and production rate is ≥90% of plant capacity.	40 minutes	%v/v	USEPA Alt-Method 008	USEPA Alt-Method 008
	Moisture			%v/v	USEPA Method 4	USEPA Method 4
A1 Dust extraction system	Total particulate matter (TPM)		As specified by AS:4323.1	mg/m ³ and g/s	USEPA Method 5 or 17	Ektimo 410
	PM ₁₀					USEPA Method 5 or 17
	PM _{2.5}					USEPA Method 5 or 17
A1 to A6	O ₂		1 minute	%v/v	USEPA Method 3A	USEPA Method 3A
	CO ₂			%v/v		

W6783/2023/1 (Amendment date: 20/03/2026)

IR-T05 Works approval template (v6.0) (September 2022)

Monitoring location	Parameter	Frequency	Averaging period	Unit	Sampling method	Analysis method ¹
	SO ₂			mg/m ³ and g/s	USEPA method 6C	USEPA method 6C
	Carbon monoxide				USEPA method 10	USEPA method 10
	Nitrogen dioxide				USEPA method 20	USEPA method 20
	Ozone				AS 3580.6.1	AS 3580.6.1
A2 to A6	Carbonyl sulfide		1 minute	mg/m ³ and g/s	Ektimo 200	Ektimo 345a
	Dimethylsulfide					
	Ethanethiol					
	Hydrogen sulfide					
A2 to A6	Methanethiol		1 minute	mg/m ³ and g/s	Ektimo 200	Ektimo 345b
	1,1,1-Trichloroethane (1,1,1-TCA, methyl chloroform, chloroethene)					
	1,1,2,2-Tetrachloroethane (acetylene tetrachloride)					
	1,1,2-Trichloro-1,2,2-trifluoroethane (freon 113' trichlorotrifluoroethane)					
	1,1,2-Trichloroethane (1,1,2-TCA, vinyl trichloride)					
	,1-Dichloroacetone					
	1,1-Dichloroethane (1,1-DCA)					
	1,1-Dichloroethene (1,1-DCE, vinylidene chloride)					
	1,1-Dichloroethylene					
	1,2 Dibromoethane (ethylene dibromide, EDB)					
	1,2,4-Trichlorobenzene (1,2,4-TCB)					
	1,2,4-Trimethylbenzene (1,2,4-TMB, pseudo-cumene)					
	1,2-Dibromoethene					
	1,2-Dichlorobenzene (o-dichlorobenzene)					
1,2-Dichloroethane (1,2-DCA, ethylene dichloride);						
1,2-Dichloropropane (propylene dichloride)						

Monitoring location	Parameter	Frequency	Averaging period	Unit	Sampling method	Analysis method ¹
	1,2-Dichlorotetrafluoroethane (freon-114)					
	1,3,5-Trimethylbenzene (1,3,5-TMB, mesitylene)					
	1,3-Butadiene					
	1,3-Dichlorobenzene (m-dichlorobenzene)					
	1,4-Dichlorobenzene (p-dichlorobenzene)					
	1,4-Dioxane; 4-Ethyltoluene					
	4-Methyl-2-pentanone (methyl isobutyl ketone, MIBK)					
	Acetone					
	Acrolein (2-propenal)					
	Benzene					
	Benzylchloride (chloromethylbenzene)					
	Bromodichloromethane (dichlorobromomethane)					
	Bromoform (tribromomethane)					
	Bromomethane (methylbromide)					
	Butanone (methyl ethyl ketone, MEK, 2-butanone)					
	Carbon disulfide					
	Carbon tetrachloride (tetrachloromethane)					
	Chlorobenzene (benzene chloride, monochlorobenzene)					
	Chloroethane					
	Chloromethane					
	Cyclohexane					
	Dibromochloromethane (chlorodibromomethane)					
	Dichlorodifluoromethane (freon-12)					
	Dichloromethane (DCM, methylene chloride)					
	Diethyl ether					
	Ethanol					
	Ethylacetate					

Monitoring location	Parameter	Frequency	Averaging period	Unit	Sampling method	Analysis method ¹
	Ethylbenzene					
	Heptane (n-heptane)					
	Hexachloro-1,3-butadiene (hexachlorobutadiene, HCBd)					
	Hexane (n-hexane)					
	Methyl butyl ketone					
	Methyl tert-butyl ether (MTBE)					
	Methylmethacrylate					
	Naphthalene					
	Propan-2-ol (isopropyl alcohol, isopropanol, 2-propanol)					
	Propene (propylene)					
	Propionaldehyde (propanal)					
	Styrene (ethenyl benzene)					
	Tetrachloroethene (perchloroethylene, perchloroethene, tetrachloroethylene)					
	Tetrahydrofuran (THF)					
	Toluene					
	Total organic compounds (as hexane equivalent)					
	Trichloroethene (trichloroethylene, TCE)					
	Trichlorofluoromethane (freon-11, trichloromonofluoromethane)					
	Trichloromethane (chloroform)					
	Vinyl acetate					
	Vinyl chloride					
	cis-1,2-Dichloroethylene					
	cis-1,3-Dichloropropene (cis-1,3- dichloropropylene)					
	m-Xylene					
	o-Xylene					
	p-Xylene					

Monitoring location	Parameter	Frequency	Averaging period	Unit	Sampling method	Analysis method ¹
	trans-1,2-Dichloroethene (trans-1,2-DCE, trans-1,2-dichloroethylene)					
	trans-1,3-Dichloropropene (trans-1,3-dichloropropylene)					
A2 to A6	2,5-Dimethylbenzaldehyde		40 minutes	mg/m ³ and g/s	Ektimo 330	Ektimo 330
	2-Methylbenzaldehyde (o-tolualdehyde)					
	2-Methylpropanal (isobutyraldehyde)					
	3-Methylbenzaldehyde (m-tolualdehyde)					
	3-Methylbutanal (isovaleraldehyde)					
	4-Methylbenzaldehyde (p-tolualdehyde)					
	Acetaldehyde (ethanal)					
	Acetone					
	Acrolein (2-propenal)					
	Benzaldehyde (phenylmethanal)					
	Butanone (methyl ethyl ketone, MEK, 2-butanone)					
	Crotonaldehyde					
	Formaldehyde (methanal)					
	Hexanal (hexaldehyde)					
	Pentanal (valeraldehyde)					
	Propionaldehyde (propanal)					
	n-Butyraldehyde					

Note 1: Each emission point must be assessed against Australian Standard AS4323.1.

Note 2: Gas volumes and concentrations to be expressed on a dry basis at 0 °C, at discharge oxygen concentration and an absolute pressure of 101.325 kPa